



Highlights

# Telescopic slides



Standard Parts. **Ganter.**



# Contents

---

## Telescopic slides

General notes	→ Page	2
Overview of types	→ Page	4
<hr/>		
Telescopic slides with partial extension GN 1400	→ Page	6
Telescopic slides with partial extension GN 1404	→ Page	8
Telescopic slides with full extension GN 1408	→ Page	10
Telescopic slides with full extension GN 1410	→ Page	13
Telescopic slides with full extension GN 1412	→ Page	16
Telescopic slides with full extension GN 1414	→ Page	19
Telescopic slides with full extension GN 1418	→ Page	22
Telescopic slides with full extension GN 1420	→ Page	25
Telescopic slides with full extension GN 1422	→ Page	27
Telescopic slides with full extension GN 1424	→ Page	30
Telescopic slides with full extension GN 1426	→ Page	33
Telescopic slides with full extension GN 1430	→ Page	35
Telescopic slides with full extension GN 1432	→ Page	37
Telescopic slides with full extension GN 1440	→ Page	40
St. Steel-Telescopic slides with full extension GN 1450	→ Page	43
St. Steel-Telescopic slides with full extension GN 1460	→ Page	46
<hr/>		
Mounting information	→ Page	49
Technical information	→ Page	51
Component options	→ Page	53
Fastening options	→ Page	57

The publication of this catalogue renders all previous editions invalid. All editions meet the best available technology during printing. We reserve the right to make technical modifications or modifications resulting from an error as well as the right to remove individual items from the product range. The products of this catalogue were developed as standard parts with the aim of covering the widest possible spectrum of requirements. We shall not assume any responsibility or liability for special applications with extraordinary requirements on our products. Our design department will gladly answer questions on certain product features, such as missing tolerances, dimensions, and stability. We will deliver based on our terms and conditions of payment and delivery. Download is available at [www.ganternorm.com](http://www.ganternorm.com).  
Otto Ganter GmbH & Co. KG has all rights to the catalogue. Reproduction, including excerpts, is prohibited.  
Otto GANTER GmbH & Co. KG, February 2020

## General information

Telescopic slides offer smooth running, wear-free, and quiet linear motion. They are used in a very wide range of applications. The spectrum ranges from the most simple extensions and drawers to high-quality variants that are used in the industrial environment on machines, production systems, and equipment. The telescopic slides have a multitude of positive features and are still very interesting from an economic standpoint.

Here are a few examples of use: sliding doors, protective hoods, keyboards and PC pullouts, vehicle equipment, storage shelves, battery boxes etc.

Telescopic slides can come with a number of component options. Some are available for one of the two stop positions and in combination, and they are defined by the type in the article number.

## Structure

Telescopic slides consist of an outer and inner slide as well as additionally of one or two middle slides depending on design and/or required extension lengths. The slides are interconnected through appropriately shaped geometry and move by means of ball bearings. A ball cage keeps the bearings spaced and in position.

The slides are usually mounted through countersunk holes or through-holes. Other options, such as threaded bolts or support brackets, are available as an alternative.

In regard to the length of the extension, telescopic slides can be divided into three categories: partial extension, full extension, and over extension. The categories are defined by the achievable stroke  $l_2$ , which is listed in relation to the nominal length  $l_1$ .

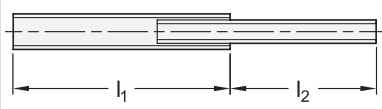
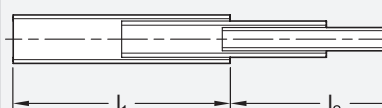
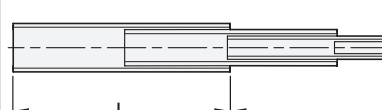
Type of extension	Extension diagram
Partial extension: $l_1 = 100\% \rightarrow l_2 = \text{min. } 75\%$	 A schematic diagram of a telescopic slide in a partially extended state. The inner slide is pulled out from the outer slide. Dimension lines below the diagram indicate the nominal length $l_1$ (the length of the outer slide) and the achievable stroke $l_2$ (the length of the inner slide).
Full extension: $l_1 = 100\% \rightarrow l_2 = \text{min. } 100\%$	 A schematic diagram of a telescopic slide in a fully extended state. The inner slide is pulled out such that its length matches the nominal length $l_1$ of the outer slide. Dimension lines below the diagram indicate $l_1$ and $l_2$ .
Over extension: $l_1 = 100\% \rightarrow l_2 = \text{min. } 150\%$	 A schematic diagram of a telescopic slide in an over-extended state. The inner slide is pulled out further than the nominal length $l_1$ of the outer slide. Dimension lines below the diagram indicate $l_1$ and $l_2$ .

All slides have internally constructed stops in the front and back end position. The stops prevent the slides from extending unintentionally. Depending on the available installation space and required stability, the stops are designed accordingly in a metallic form or with additional plastic or elastomer parts as a rubber stop to prevent the slides from hitting the end positions with too much force.

Also the telescopic slides can come with a variety of accessory functions. Examples include locking devices, latches, detach functions, and self-retracting mechanisms, some of which are dampened. Some additional functions are available, depending on slide variant, for the back or front stop position and in combination. Furthermore, customer-specific modifications regarding the fastening of the slides can be made.

## Telescopic slides with full extension, back stop position

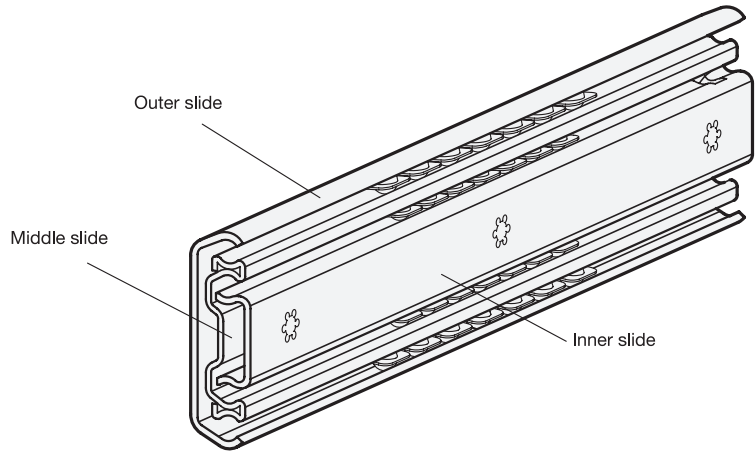

## Telescopic slides with full extension, front stop position

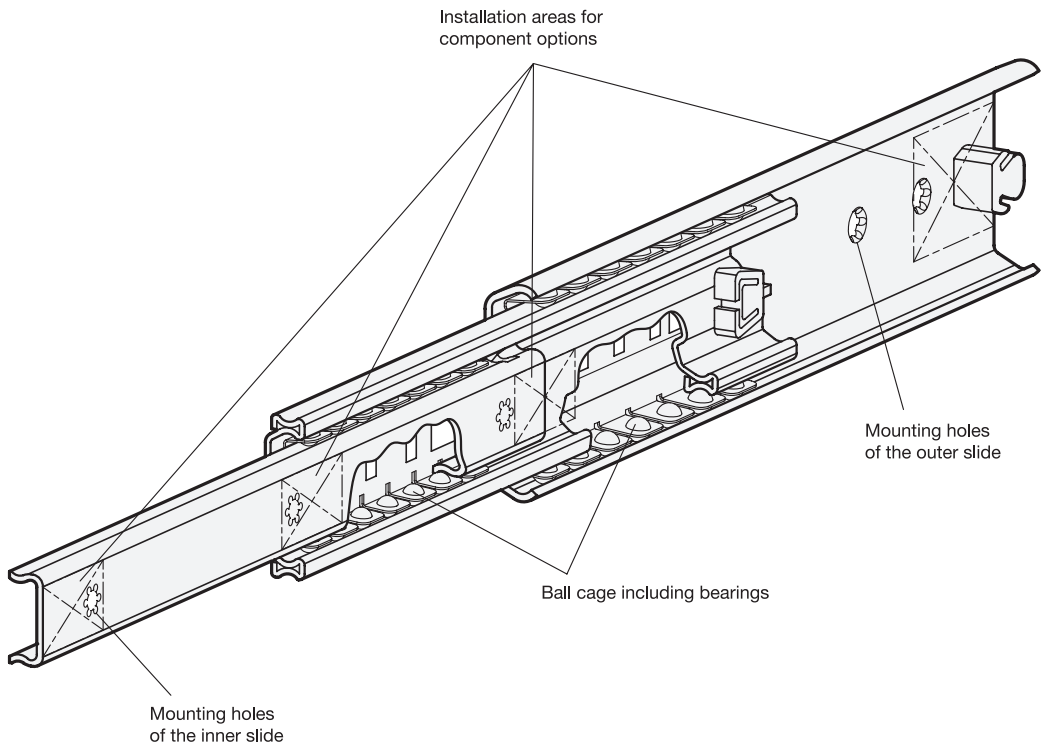

Standard	Type of extension		Load capacity per pair at 10,000 cycles in N	Basic length retracted position in mm	Material Steel <b>ST</b> St. Steel <b>NI</b>	Fastening		Outer slide, through-holes / Inner slide, countersunk holes (ld. no. 3)
	Partial extension <b>T</b> Full extension <b>V</b>					Through-holes (ld. no. 1)	Countersunk holes (ld. no. 2)	
<b>GN 1400</b> Page 6	T		280	300 - 500	ST	×		
<b>GN 1404</b> Page 8	T		780	300 - 700	ST			×
<b>GN 1408</b> Page 10	V		250	250 - 700	ST	×		
<b>GN 1410</b> Page 13	V		510	250 - 800	ST	×		
<b>GN 1412</b> Page 16	V		430	300 - 700	ST	×		
<b>GN 1414</b> Page 19	V		360	300 - 650	ST	×		
<b>GN 1418</b> Page 22	V		430	350 - 650	ST	×		
<b>GN 1420</b> Page 25	V		1290	300 - 1200	ST		×	
<b>GN 1422</b> Page 27	V		1290	300 - 800	ST		×	
<b>GN 1424</b> Page 30	V		750	350 - 700	ST		×	
<b>GN 1426</b> Page 33	V		1380	500 - 800	ST		×	
<b>GN 1430</b> Page 35	V		2120	400 - 1200	ST		×	
<b>GN 1432</b> Page 37	V		2300	400 - 800	ST		×	
<b>GN 1440</b> Type B Page 40	V		3250	300 - 1500	ST	×		
<b>GN 1440</b> Type M Page 40	V		3250	300 - 1500	ST	×		
<b>GN 1440</b> Type K Page 40	V		3250	300 - 1500	ST	×		
<b>GN 1440</b> Type Q Page 40	V		3250	300 - 1500	ST	×		
<b>GN 1450</b> Page 43	V		510	300 - 600	NI	×		
<b>GN 1460</b> Page 46	V		1050	250 - 800	NI		×	

Standard	Component features									
	without rubber stop	with rubber stop back-front	Locking device back Type E	Locking device back, detach function Type F	Latch back Type M	Latch front Type K	Latch back-front Type Q	Self-retracting mechanism, dampened / not dampened	Push to open - mechanism	Extension on both sides
<b>GN 1400</b> Page 6	×									
<b>GN 1404</b> Page 8		×	×							
<b>GN 1408</b> Page 10		×		×						
<b>GN 1410</b> Page 13		×		×						
<b>GN 1412</b> Page 16		×		×				×		
<b>GN 1414</b> Page 19		×		×				×		
<b>GN 1418</b> Page 22		×		×					×	
<b>GN 1420</b> Page 25		×	×							
<b>GN 1422</b> Page 27		×						×		
<b>GN 1424</b> Page 30		×						×		
<b>GN 1426</b> Page 33		×								×
<b>GN 1430</b> Page 35		×	×							
<b>GN 1432</b> Page 37		×						×		
<b>GN 1440</b> Type B Page 40		×								
<b>GN 1440</b> Type M Page 40		×			×					
<b>GN 1440</b> Type K Page 40		×				×				
<b>GN 1440</b> Type Q Page 40		×					×			
<b>GN 1450</b> Page 43		×		×						
<b>GN 1460</b> Page 46		×		×						

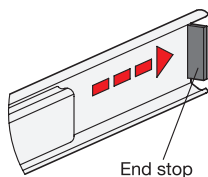
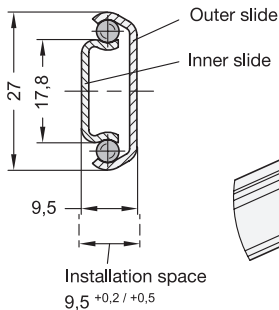
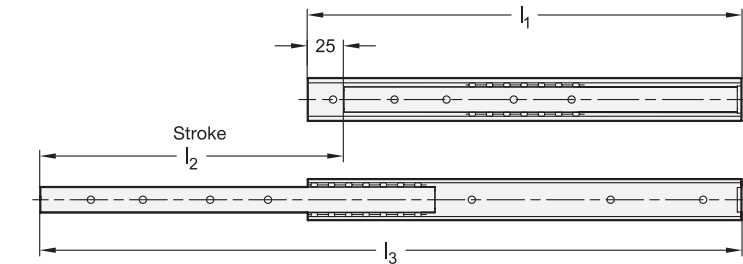

Fastening screws

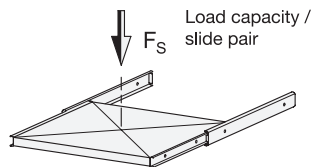
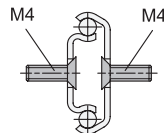

**2 Type**

**A** without rubber stop

**3 Identification no.**

**1** Fastening using through-holes

**1**

$l_1$	$l_2$ <sup>+2</sup> <sub>-2</sub> Stroke	$l_3$	$F_S$ per pair in N	
			at 10,000 cycles	at 100,000 cycles
300	210	485	220	170
350	240	565	260	200
400	290	665	260	200
500	370	845	280	220

**Specification**

- Slide profile  
Steel, zinc plated, blue passivated **ZB**
- Bearings  
Roller bearing steel, hardened
- Ball cage  
Steel, zinc plated
- Operating temperature -20 °C to 100 °C
- RoHS

**On request**

- other lengths and hole spacing
- other attachment options
- with rubber stop
- with locking device (back, front, or back-front)
- other surfaces
- with support bracket
- with retraction dampening, external

**4**

**Information**

Telescopic slides GN 1400 are installed vertically and in pairs. The stroke reaches  $\approx 75\%$  of the nominal length  $l_1$  (partial extension). With type A without rubber stop, the end stops are made out of steel, which prevents the slide from being unintentionally pulled out or detached. If larger static or dynamic loads occur in the direction of extension, they should be absorbed by external stop elements.

The telescopic slides are delivered in **pairs**. They can be installed on the extension on either the left or right side due to the mechanics. All mounting holes are easy to reach without additional auxiliary holes. Only the mounting holes are shown, but other production-related holes may be present.

see also...

- *Technical information on telescopic slides* → Page 51 ff.
- *Telescopic slides (with full extension)* → Page 12 ff.
- *Stainless Steel-Telescopic slides (with full extension)* → Page 43 ff.

How to order

**GN 1400-400-A-1-ZB**

<b>1</b>	$l_1$
<b>2</b>	Type
<b>3</b>	Identification no.
<b>4</b>	Finish



## Mounting holes - outer slide

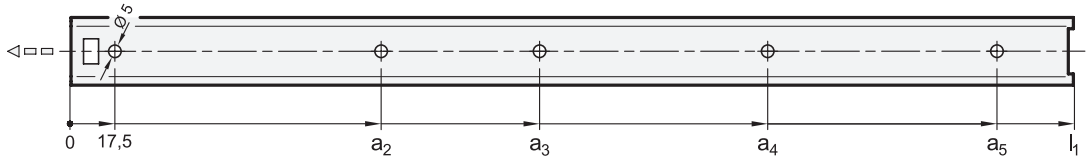

$l_1$	$a_2$	$a_3$	$a_4$	$a_5$
300	113,5	209,5	273,5	-
350	113,5	209,5	337,5	-
400	113,5	209,5	369,5	-
500	145,5	209,5	337,5	465,5

## Mounting holes - inner slide

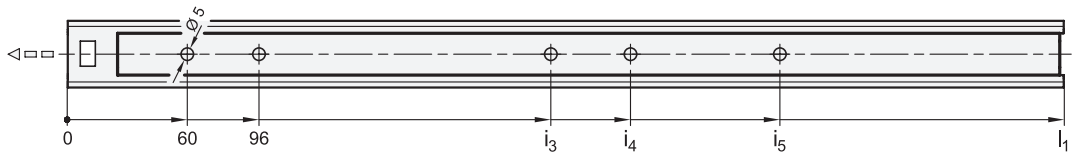

$l_1$	$i_3$	$i_4$	$i_5$
300	142,5	182,5	-
350	167,5	207,5	-
400	192,5	232,5	282,5
500	242,5	282,5	357,5

## Fastening screws

For the said loading forces  $F_S$  to be absorbed reliably in the surrounding structure, all available through-holes of the outer and inner slide must be used. Failure to use fastening screws reduces the specified load capacity accordingly. The following screws can be used for mounting:

Designation - standard		Outer slide	Inner slide
Countersunk screw, Phillips	DIN 965	M 4	M 4
Countersunk screw, Phillips	DIN 7997	Size 3,5 / 4	Size 3,5

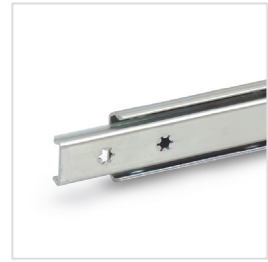
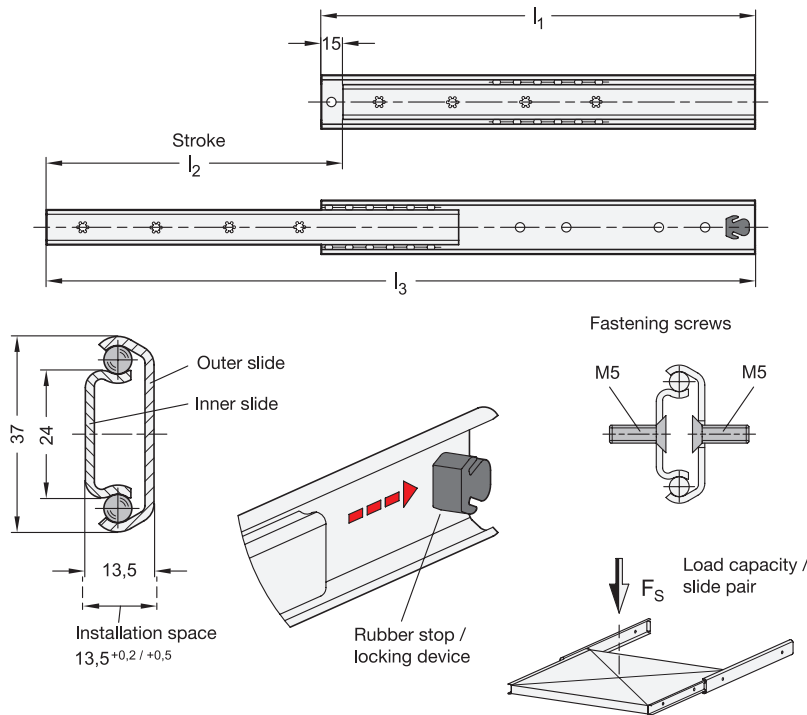

- 2 Type**  
E with rubber stop, locking device in back
- 3 Identification no.**  
3 Fastening using through-holes on external slide and countersunk holes on inner slide



$l_1$	$l_2$ <sup>+2</sup> / <sub>-2</sub> Stroke	$l_3$	$F_S$ per pair in N	
			at 10,000 cycles	at 100,000 cycles
300	205	490	780	600
350	239	574	630	490
400	289	674	540	420
450	339	774	460	360

$l_1$	$l_2$ <sup>+2</sup> / <sub>-2</sub> Stroke	$l_3$	$F_S$ per pair in N	
			at 10,000 cycles	at 100,000 cycles
500	373	858	540	420
600	457	1042	560	430
700	541	1226	560	430

**Specification**



- Slide profile  
Steel, zinc plated, blue passivated **ZB**
- Bearings  
Roller bearing steel, hardened
- Ball cage  
Steel, zinc plated
- Rubber stop  
Plastic / Elastomer
- Operating temperature -20 °C to 100 °C
- **RoHS**

**On request**

- other lengths and hole spacing
- other attachment options
- with rubber stop (without locking device)
- other surfaces
- with support bracket
- retraction dampening, external

**Information**

Telescopic slides GN 1404 are installed vertically and in pairs. The stroke reaches  $\approx 75\%$  of the nominal length  $l_1$  (partial extension). The rubber stops of type E dampen the impact of the slide in the two end positions and takes on the locking function of the back stop position. This feature is noticeable through a slight resistance on opening and closing. If larger static or dynamic loads occur in the direction of extension, they should be absorbed by external stop elements.

The telescopic slides are delivered in **pairs**. They can be installed on the extension on either the left or right side due to the mechanics. All mounting holes are easy to reach without auxiliary holes. Only the mounting holes are shown, but other production-related holes may be present.

see also...

- *Technical information on telescopic slides* → Page 51 ff.
- *Telescopic slides (with full extension)* → Page 12 ff.

**How to order**

**GN 1404-600-E-3-ZB**

1	$l_1$
2	Type
3	Identification no.
4	Finish

## Mounting holes - outer slide

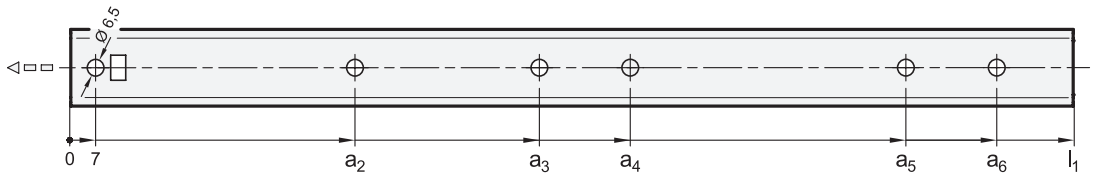

$l_1$	$a_2$	$a_3$	$a_4$	$a_5$	$a_6$
300	135	199	231	-	-
350	135	231	263	-	-
400	135	295	327	-	-
450	135	327	359	-	-
500	167	295	327	391	423
600	167	359	391	487	519
700	199	391	423	583	615

## Mounting holes - inner slide

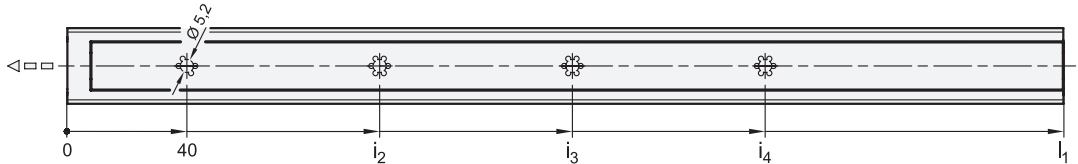

$l_1$	$i_2$	$i_3$	$i_4$
300	72	136	168
350	104	168	200
400	104	200	264
450	104	200	296
500	136	232	328
600	168	296	424
700	168	328	520

## Fastening screws

For the said loading forces  $F_3$  to be absorbed reliably in the surrounding structure, all available through-holes and/or countersunk holes of the outer and inner slide must be used. Failure to use fastening screws reduces the specified load capacity accordingly. The following screws can be used for mounting:

Designation - standard		Outer slide	Inner slide
Countersunk screw, Phillips	DIN 965	M 5	M 5
Countersunk screw, Phillips	DIN 7997	Size 5	Size 4,5

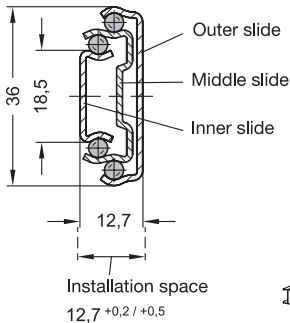
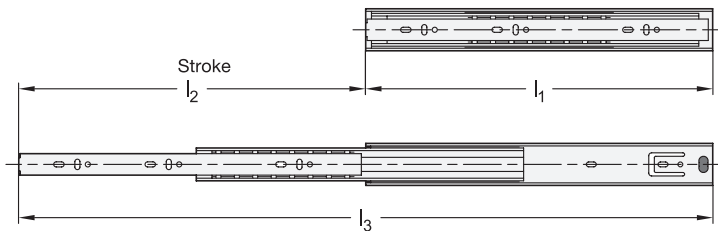

Fastening screws

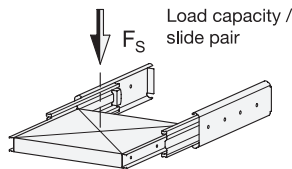
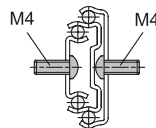

**2 Type**

**F** with rubber stop, locking device in back, detach function

**3 Identification no.**

**1** Fastening using through-holes

**1**

l <sub>1</sub>	l <sub>2</sub> <sup>+3</sup> Stroke	l <sub>3</sub>	F <sub>S</sub> per pair in N	
			at 10,000 cycles	at 100,000 cycles
250	250	500	200	150
300	300	600	200	150
350	350	700	220	180
400	400	800	250	200
450	450	900	250	200

**1**

l <sub>1</sub>	l <sub>2</sub> <sup>+3</sup> Stroke	l <sub>3</sub>	F <sub>S</sub> per pair in N	
			at 10,000 cycles	at 100,000 cycles
500	500	1000	220	180
550	550	1100	220	180
600	600	1200	200	150
650	650	1300	200	150
700	700	1400	200	150

**Specification**

- Slide profile  
Steel, zinc plated, blue passivated **ZB**
- Bearings  
Roller bearing steel, hardened
- Ball cage, outer slide  
Plastic
- Ball cage, inner slide  
Steel, zinc plated
- Rubber stop and detach function  
Plastic / Elastomer
- Operating temperature -20 °C to 100 °C
- RoHS

**On request**

- other lengths and hole spacing
- other attachment options
- other surfaces

**4**

**Information**

Telescopic slides GN 1408 are installed vertically and in pairs. The stroke reaches ≈ 100 % of the nominal length l<sub>1</sub> (full extension).

The telescopic slides are delivered in **pairs**. They can be installed on the extension on either the left or right side due to the mechanics. All mounting holes are easy to reach through auxiliary holes. Only the mounting holes are shown, but other production-related holes may be present.

see also...

- Technical information on telescopic slides → Page 51 ff.
- Telescopic slides GN 1410 (with full extension) → Page 13
- Stainless Steel-Telescopic slides GN 1450 (with full extension) → Page 43
- Telescopic slides GN 1400 (with partial extension) → Page 6

How to order

**GN 1408-600-F-1-ZB**

<b>1</b>	l <sub>1</sub>
<b>2</b>	Type
<b>3</b>	Identification no.
<b>4</b>	Finish

## Mounting holes - outer slide

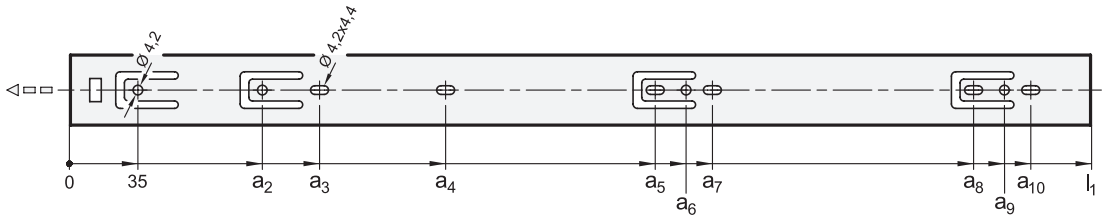

$l_1$	$a_2$	$a_3$	$a_4$	$a_5$	$a_6$	$a_7$	$a_8$	$a_9$	$a_{10}$
250	-	65	-	195	210	225	-	-	-
300	99	129	195	257	272	-	-	-	-
350	99	129	185	259	274	289	-	-	-
400	99	129	-	259	274	-	323	338	353
450	99	129	185	259	274	289	387	402	417
500	99	129	185	291	306	321	451	466	481
550	99	129	185	323	338	353	483	498	513
600	99	129	185	323	338	353	515	530	545
650	99	129	185	355	370	385	579	594	609
700	99	129	185	387	402	417	643	658	673

## Mounting holes - inner slide

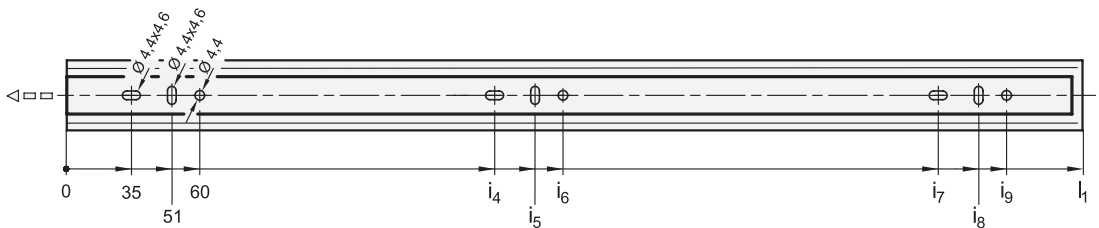

$l_1$	$i_4$	$i_5$	$i_6$	$i_7$	$i_8$	$i_9$
250	195	211	220	-	-	-
300	114	130	139	227	243	252
350	163	179	188	291	307	316
400	163	179	188	355	371	380
450	195	211	220	387	403	412
500	227	243	252	451	467	476
550	259	275	284	483	499	508
600	259	275	284	515	531	540
650	291	307	316	579	595	604
700	323	339	348	643	659	668

## Fastening screws

For the said loading forces  $F_S$  to be absorbed reliably in the surrounding structure, all available through-holes of the outer slide having a diameter ( $\varnothing$ ) of 4.2 and of the inner slide having a diameter ( $\varnothing$ ) of 4.4 must be used. The elongated holes,  $\varnothing 4.2 \times 4.4$  of the outer slide and  $\varnothing 4.4 \times 4.6$  of the inner slide, are used likewise for fastening and facilitate adjustment during mounting when needed. Failure to use fastening screws reduces the specified load capacity accordingly. The following screws can be used for mounting:

Designation - standard		Outer slide	Inner slide
Hexagon socket button head screw	ISO 7380	M 4	M 4
Pan head screw, Phillips	ISO 7045	M 4	M 4
Pan head tapping screw, Phillips	ISO 7049	ST 3,9 / 4,2	ST 3,9 / 4,2

## Rubber stop, locking device in back

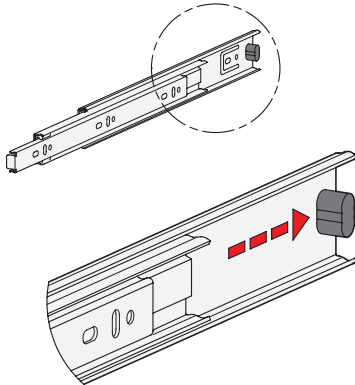

The rubber stops of type F dampen the impact of the slide in the respective end position. This feature minimizes noise development and increases the lifespan. Attached to the slides in a partially concealed, partially visible manner, the stops meet each of the requirements in regard to shape, material, and hardness.

In the back stop position, the rubber stop takes on additionally a locking function, which is noticeable through a slight resistance on opening and closing.

If larger static or dynamic loads occur in the direction of extension, they should be absorbed by external stop elements.

## Detach function

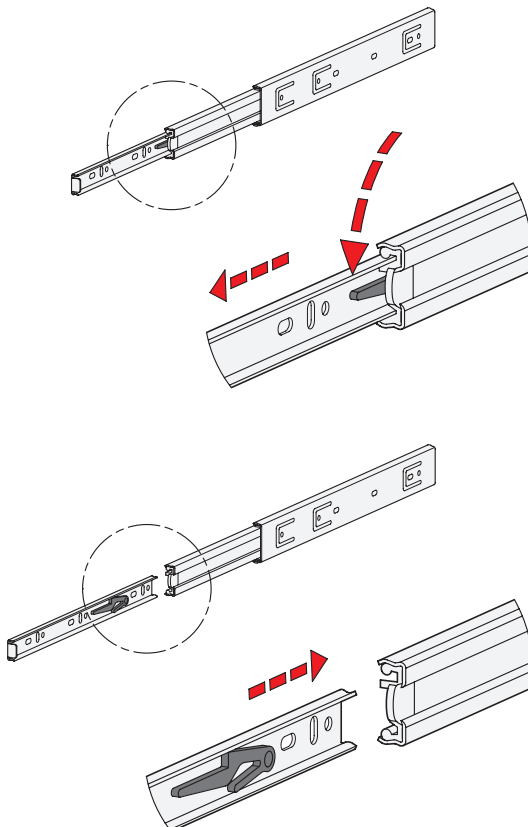

Type F has additionally a detach function through which the extension slides can be completely separated from one another in the area of the middle and inner slide. This feature not only facilitates mounting. It also allows the extension to be quickly removed, for example, when frequent maintenance work is performed on the components located behind.

The telescopic slide can be quickly and easily detached in the extracted position through activation of the release lever, allowing the inner slide to be removed from the front.

For reattaching the slides, the ball cages need to be moved to the front end position. Then the inner slide is inserted to the back end stop where it locks into place automatically.

The protected arrangement of the release mechanism prevents accidental detachment of the slide.

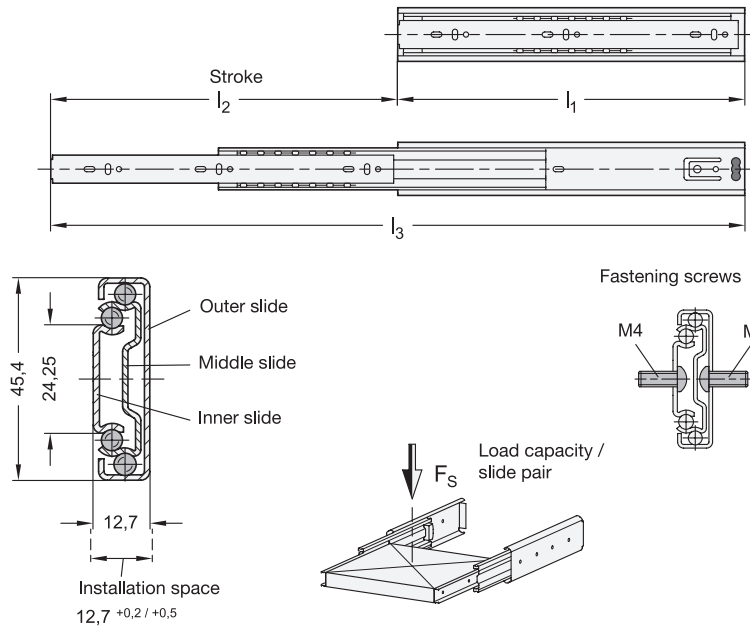

**2 Type**

**F** with rubber stop, locking device in back, detach function

**3 Identification no.**

**1** Fastening using through-holes

Fastening screws

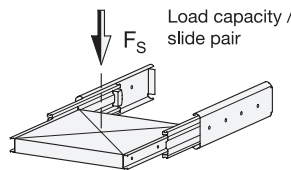
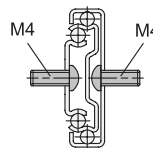

**1**

l <sub>1</sub>	l <sub>2</sub> <sup>+3</sup> Stroke	l <sub>3</sub>	F <sub>S</sub> per pair in N	
			at 10,000 cycles	at 100,000 cycles
250	250	500	450	320
300	300	600	460	340
350	350	700	480	360
400	400	800	510	390
450	450	900	510	390
500	500	1000	480	360

**1**

l <sub>1</sub>	l <sub>2</sub> <sup>+3</sup> Stroke	l <sub>3</sub>	F <sub>S</sub> per pair in N	
			at 10,000 cycles	at 100,000 cycles
550	550	1100	460	340
600	600	1200	440	340
650	650	1300	420	320
700	700	1400	420	320
750	750	1500	400	300
800	800	1600	400	300

**Specification**

- Slide profile  
Steel, zinc plated, blue passivated **ZB**
- Bearings  
Roller bearing steel, hardened
- Ball cage, outer slide  
Plastic
- Ball cage, inner slide  
Steel, zinc plated
- Rubber stop and detach function  
Plastic / Elastomer
- Operating temperature -20 °C to 100 °C
- RoHS

**4**

**Information**

Telescopic slides GN 1410 are installed vertically and in pairs. The stroke reaches ≈ 100 % of the nominal length l<sub>1</sub> (full extension).

The telescopic slides are delivered in **pairs**. They can be installed on the extension on either the left or right side due to the mechanics. All mounting holes are easy to reach through auxiliary holes. Only the mounting holes are shown, but other production-related holes may be present.

see also...

- Technical information on telescopic slides → Page 51 ff.
- Stainless Steel-Telescopic slides GN 1450 (with full extension) → Page 43
- Telescopic slides GN 1412 (with self-retracting mechanism) → Page 16

**On request**

- other lengths and hole spacing
- other attachment options
- other surfaces

How to order

**GN 1410-250-F-1-ZB**

1	l <sub>1</sub>
2	Type
3	Identification no.
4	Finish

## Mounting holes - outer slide

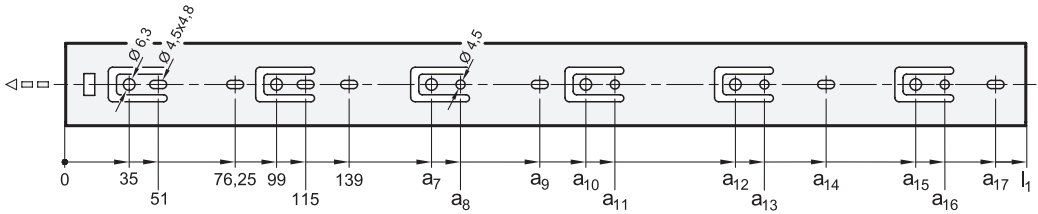

$l_1$	$a_7$	$a_8$	$a_9$	$a_{10}$	$a_{11}$	$a_{12}$	$a_{13}$	$a_{14}$	$a_{15}$	$a_{16}$	$a_{17}$
250	183	199	-	-	-	-	-	-	-	-	-
300	259	275	-	-	-	-	-	-	-	-	-
350	259	275	309	-	-	-	-	-	-	-	-
400	259	275	-	323	339	-	-	373	-	-	-
450	259	275	361,5	387	403	-	-	-	-	-	-
500	259	275	361,5	387	403	451	467	-	-	-	-
550	259	275	361,5	387	403	451	467	501	-	-	-
600	259	275	361,5	387	403	515	531	565	-	-	-
650	259	275	361,5	387	403	579	595	629	-	-	-
700	259	275	361,5	387	403	579	595	629	-	-	-
750	259	275	361,5	387	403	547	563	597	643	659	693
800	259	275	361,5	387	403	579	595	629	707	723	757

## Mounting holes - inner slide

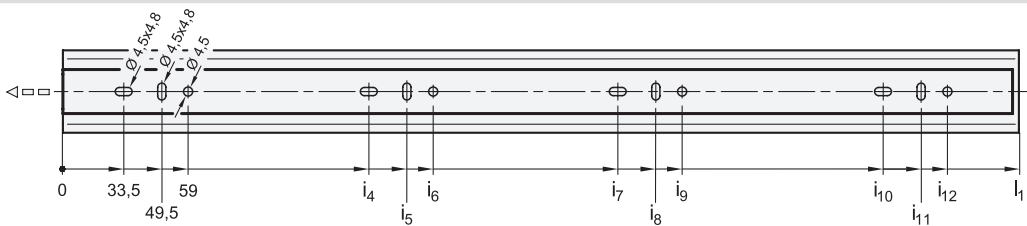

$l_1$	$i_4$	$i_5$	$i_6$	$i_7$	$i_8$	$i_9$	$i_{10}$	$i_{11}$	$i_{12}$
250	209,5	225,5	235	-	-	-	-	-	-
300	129,5	145,5	155	257,5	273,5	283	-	-	-
350	161,5	177,5	187	289,5	305,5	315	-	-	-
400	193,5	209,5	219	353,5	369,5	379	-	-	-
450	193,5	209,5	219	385,5	401,5	411	-	-	-
500	225,5	241,5	251	449,5	465,5	475	-	-	-
550	257,5	273,5	283	481,5	497,5	507	-	-	-
600	289,5	305,5	315	545,5	561,5	571	-	-	-
650	321,5	337,5	347	609,5	625,5	635	-	-	-
700	321,5	337,5	347	609,5	625,5	635	-	-	-
750	193,5	209,5	219	321,5	337,5	347	673,5	689,5	699
800	193,5	209,5	219	353,5	369,5	379	705,5	721,5	731

## Fastening screws

For the said loading forces  $F_S$  to be absorbed reliably in the surrounding structure, all available through-holes of the outer and inner slide having a diameter ( $\varnothing$ ) of 4.5 must be used. Alternatively, the outer slide has holes with a diameter ( $\varnothing$ ) of 6.3 for Euro screws. The elongated holes,  $\varnothing 4.5 \times 4.8$ , are used likewise for fastening and facilitate adjustment during mounting when needed. Failure to use fastening screws reduces the specified load capacity accordingly. The following screws can be used for mounting:

Designation - standard		Outer slide	Inner slide
Hexagon socket button head screw	ISO 7380	M 4	M 4
Pan head screw, Phillips	ISO 7045	M 4	M 4
Pan head tapping screw, Phillips	ISO 7049	ST 3,9 / 4,2	ST 3,9 / 4,2



## Rubber stop, locking device in back

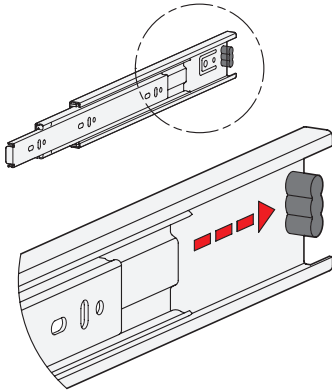

The rubber stops of type F dampen the impact of the slide in the respective end position. This feature minimizes noise development and increases the lifespan. Attached to the slides in a partially concealed, partially visible manner, the stops meet each of the requirements in regard to shape, material, and hardness.

In the back stop position, the rubber stop takes on additionally a locking function, which is noticeable through a slight resistance on opening and closing.

If larger static or dynamic loads occur in the direction of extension, they should be absorbed by external stop elements.

## Detach function

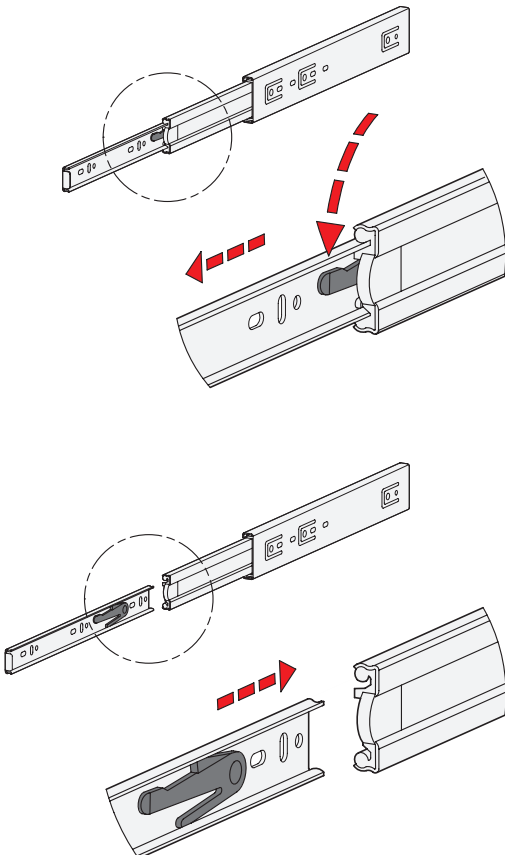

Type F has additionally a detach function through which the extension slides can be completely separated from one another in the area of the middle and inner slide. This feature not only facilitates mounting. It also allows the extension to be quickly removed, for example, when frequent maintenance work is performed on the components located behind.

The telescopic slide can be quickly and easily detached in the extracted position through activation of the release lever, allowing the inner slide to be removed from the front.

For reattaching the slides, the ball cages need to be moved to the front end position. Then the inner slide is inserted to the back end stop where it locks into place automatically.

The protected arrangement of the release mechanism prevents accidental detachment of the slide.

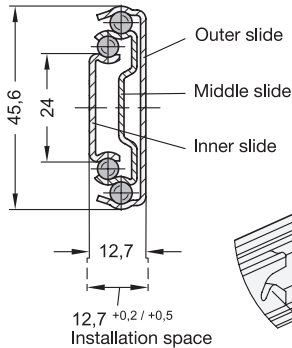
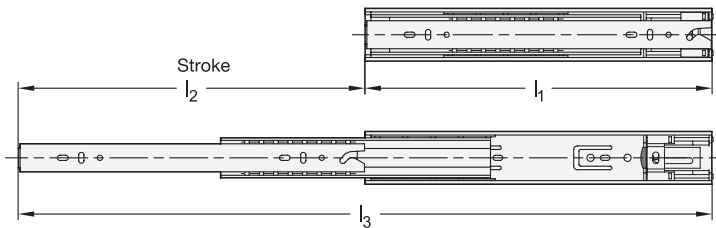

Fastening screws

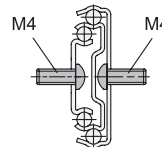

**2 Type**

**F** with rubber stop, locking device in back, detach function

**3 Identification no.**

**1** Fastening using through-holes

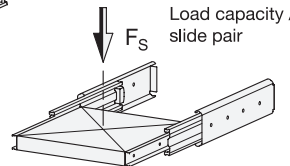
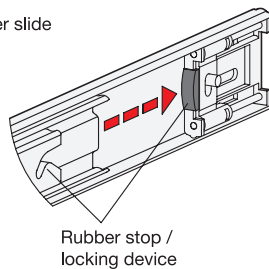

**1**

$l_1$	$l_2$ <sup>+3</sup> Stroke	$l_3$	$F_S$ per pair in N	
			at 10,000 cycles	at 100,000 cycles
300	300	600	330	240
350	350	700	380	290
400	400	800	430	340
450	450	900	430	340
500	500	1000	380	290

**1**

$l_1$	$l_2$ <sup>+3</sup> Stroke	$l_3$	$F_S$ per pair in N	
			at 10,000 cycles	at 100,000 cycles
550	550	1100	330	240
600	600	1200	320	240
650	650	1300	300	220
700	700	1400	300	220

**Specification**

- Slide profile  
Steel, zinc plated, blue passivated **ZB**
- Bearings  
Roller bearing steel, hardened
- Ball cage, outer slide  
Plastic
- Ball cage, inner slide  
Steel, zinc plated
- Rubber stop and detach function  
Plastic / Elastomer
- Self-retracting mechanism  
Zinc plated steel/plastic
- Operating temperature -20 °C to 100 °C
- RoHS

**4**

**Information**

Telescopic slides GN 1412 are installed vertically and in pairs. The stroke reaches  $\approx 100\%$  of the nominal length  $l_1$  (full extension). The rubber stops of type F dampen the impact of the slide in the end positions. This feature minimizes noise development and increases the lifespan. If larger static or dynamic loads occur in the direction of extension, they should be absorbed by external stop elements.

The telescopic slides are delivered in **pairs**. They can be installed on the extension on either the left or right side due to the mechanics. All mounting holes are easy to reach through auxiliary holes. Only the mounting holes are shown, but other production-related holes may be present.

see also...

- Technical information on telescopic slides  $\rightarrow$  Page 51 ff.
- Telescopic slides GN 1410 (with full extension)  $\rightarrow$  Page 13

**On request**

- other lengths and hole spacing
- other attachment options
- other surfaces

How to order

**GN 1412-500-F-1-ZB**

<b>1</b>	$l_1$
<b>2</b>	Type
<b>3</b>	Identification no.
<b>4</b>	Finish

## Mounting holes - outer slide

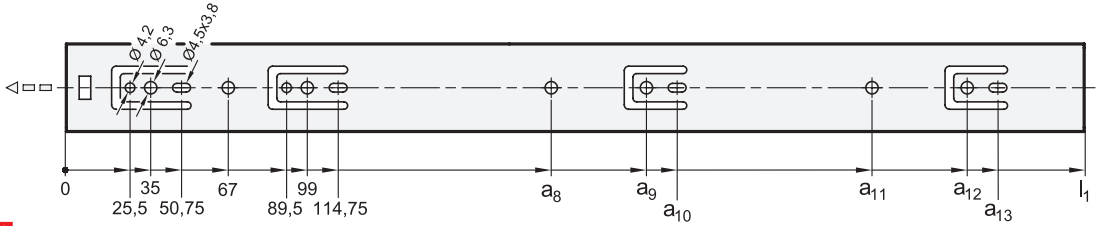

$l_1$	$a_8$	$a_9$	$a_{10}$	$a_{11}$	$a_{12}$	$a_{13}$
300	-	195	207,75	227	-	-
350	-	227	239,75	259	-	-
400	259	291	303,75	323	-	-
450	259	323	335,75	-	-	-
500	259	323	335,75	-	387	399,75
550	259	323	335,75	387	451	463,75
600	259	355	367,75	387	483	495,75
650	259	355	367,75	451	515	527,75
700	259	355	367,75	515	579	591,75

## Mounting holes - inner slide

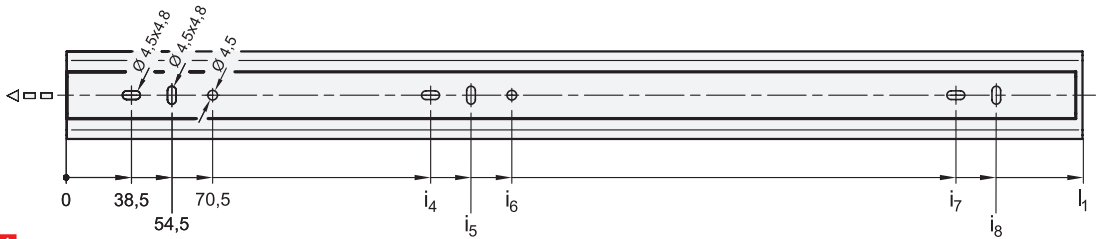

$l_1$	$i_4$	$i_5$	$i_6$	$i_7$	$i_8$
300	230,5	246,5	262,5	-	-
350	150,5	166,5	182,5	292,5	308,5
400	170,5	186,5	202,5	341,5	357,5
450	195,5	211,5	227,5	391,5	407,5
500	220,5	236,5	252,5	441,5	457,5
550	250,5	266,5	282,5	492,5	508,5
600	260,5	276,5	292,5	541,5	557,5
650	260,5	276,5	292,5	602,5	618,5
700	260,5	276,5	292,5	652,5	668,5

## Fastening screws

For the said loading forces  $F_S$  to be absorbed reliably in the surrounding structure, all available through-holes of the outer slide having a diameter ( $\varnothing$ ) of 4.2 and of the inner slide having a diameter ( $\varnothing$ ) of 4.5 must be used. Alternatively, the outer slide has holes with a diameter ( $\varnothing$ ) of 6.3 for Euro screws. The elongated holes,  $\varnothing 4.5 \times 3.8$  of the outer slide and  $\varnothing 4.5 \times 4.8$  of the inner slide, are used likewise for fastening and facilitate adjustment during mounting when needed. Failure to use fastening screws reduces the specified load capacity accordingly. The following screws can be used for mounting:

Designation - standard		Outer slide	Inner slide
Hexagon socket button head screw	ISO 7380	M 4	M 4
Pan head screw, Phillips	ISO 7045	M 4	M 4
Pan head tapping screw, Phillips	ISO 7049	ST 3,9 / 4,2	ST 3,9 / 4,2

## Self-retracting mechanism

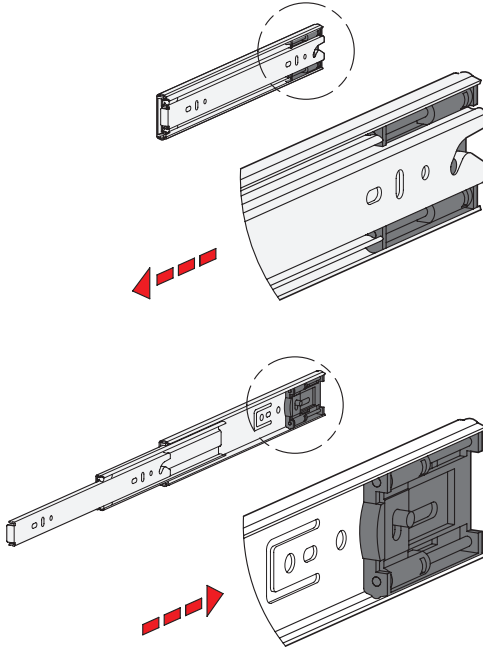

Telescopic slides GN 1412 have an integrated self-retracting mechanism, which improves considerably the ease of use when closing the extensions.

The slides are retracted and held in the back end position automatically by means of a retraction mechanism on the last 30 mm of stroke with a force of approximately 25 newtons for each slide pair.

In this slide variant the available retraction force can be regarded as a locking device, which is noticeable through a slight restriction on opening the extension.

## Detach function

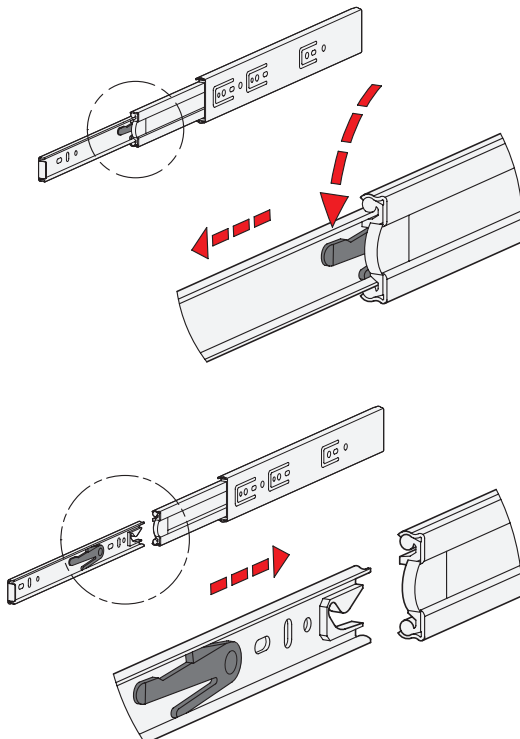

Type F has additionally a detach function through which the extension slides can be completely separated from one another in the area of the middle and inner slide. This feature not only facilitates mounting. It also allows the extension to be quickly removed, for example, when frequent maintenance work is performed on the components located behind.

The telescopic slide can be quickly and easily detached in the extracted position through activation of the release lever, allowing the inner slide to be removed from the front.

For reattaching the slides, the ball cages need to be moved to the front end position. Then the inner slide is inserted to the back end stop where it locks into place automatically.

The protected arrangement of the release mechanism prevents accidental detachment of the slide.

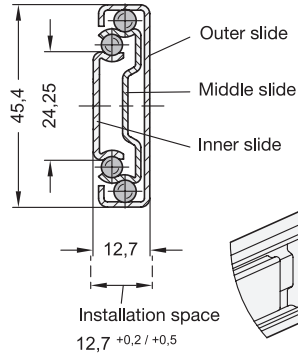
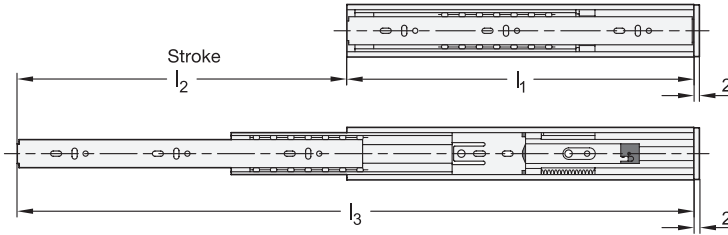

Fastening screws

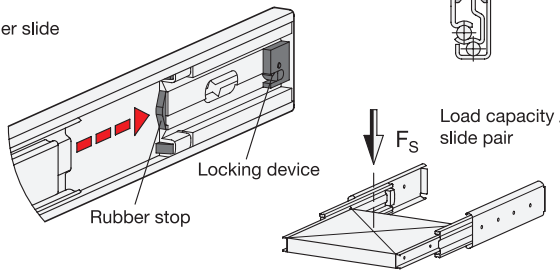
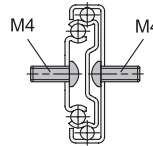

**2 Type**

**F** with rubber stop, locking device in back, detach function

**3 Identification no.**

**1** Fastening using through-holes



l <sub>1</sub>	l <sub>2</sub> <sup>+3</sup> Stroke	l <sub>3</sub>	F <sub>S</sub> per pair in N	
			at 10,000 cycles	at 100,000 cycles
300	250	550	260	140
350	320	670	260	140
400	375	775	310	190
450	450	900	360	240



l <sub>1</sub>	l <sub>2</sub> <sup>+3</sup> Stroke	l <sub>3</sub>	F <sub>S</sub> per pair in N	
			at 10,000 cycles	at 100,000 cycles
500	500	1000	360	240
550	550	1100	310	190
600	600	1200	310	190
650	650	1300	260	140

**Specification**

- Slide profile  
Steel, zinc plated, blue passivated **ZB**
- Bearings  
Roller bearing steel, hardened
- Ball cage, outer slide  
Plastic
- Ball cage, inner slide  
Steel, zinc plated
- Rubber stop and detach function  
Plastic / Elastomer
- Self-retracting mechanism, dampened  
Steel / Plastic
- Operating temperature -20 °C to 100 °C
- RoHS

**On request**

- other lengths and hole spacing
- other attachment options
- other surfaces



**Information**

Telescopic slides GN 1414 are installed vertically and in pairs. The stroke reaches ≈ 100 % of the nominal length l<sub>1</sub> (full extension). The rubber stops of type F dampen the impact of the slide in the end positions. This feature minimizes noise development and increases the lifespan. If larger static or dynamic loads occur in the direction of extension, they should be absorbed by external stop elements.

The telescopic slides are delivered in **pairs**. They can be installed on the extension on either the left or right side due to the mechanics. All mounting holes are easy to reach through auxiliary holes. Only the mounting holes are shown, but other production-related holes may be present.

see also...

- *Technical information on telescopic slides* → Page 51 ff.
- *Telescopic slides GN 1424 (with dampened self-retracting mechanism)* → Page 30
- *Telescopic slides GN 1410 (with full extension)* → Page 13

**How to order**

**GN 1414-650-B-1-ZB**

<b>1</b>	l <sub>1</sub>
<b>2</b>	Type
<b>3</b>	Identification no.
<b>4</b>	Finish

## Mounting holes - outer slide

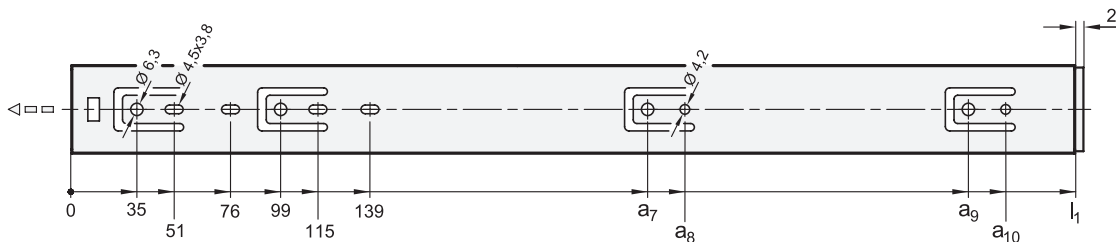

$l_1$	$a_7$	$a_8$	$a_9$	$a_{10}$
300	191,75	207,75	-	-
350	241,75	257,75	-	-
400	291,75	307,75	-	-
450	195	211	341,75	357,75
500	227	243	391,75	407,75
550	259	275	441,75	457,75
600	291	307	491,75	507,75
650	323	339	541,75	557,75

## Mounting holes - inner slide

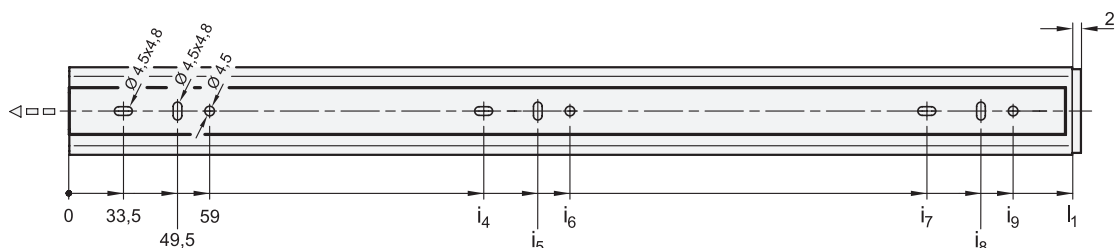

$l_1$	$i_4$	$i_5$	$i_6$	$i_7$	$i_8$	$i_9$
300	129,5	145,5	-	225,5	241,5	251
350	129,5	145,5	155	289,5	305,5	315
400	161,5	177,5	187	321,5	337,5	347
450	193,5	209,5	219	385,5	401,5	411
500	225,5	241,5	251	449,5	465,5	475
550	225,5	241,5	251	481,5	497,5	507
600	257,5	273,5	283	513,5	529,5	539
650	289,5	305,5	315	577,5	593,5	603

## Fastening screws

For the said loading forces  $F_S$  to be absorbed reliably in the surrounding structure, all available through-holes of the outer and inner slide having a diameter ( $\varnothing$ ) of 4.5 must be used. Alternatively, the outer slide has holes with a diameter ( $\varnothing$ ) of 6.3 for Euro screws. The elongated holes,  $\varnothing 4.5 \times 4.8$ , are used likewise for fastening and facilitate adjustment during mounting when needed. Failure to use fastening screws reduces the specified load capacity accordingly. The following screws can be used for mounting:

Designation - standard		Outer slide	Inner slide
Hexagon socket button head screw	ISO 7380	M 4	M 4
Pan head screw, Phillips	ISO 7045	M 4	M 4
Pan head tapping screw, Phillips	ISO 7049	ST 3,9 / 4,2	ST 3,9 / 4,2

## Self-retracting mechanism, dampened

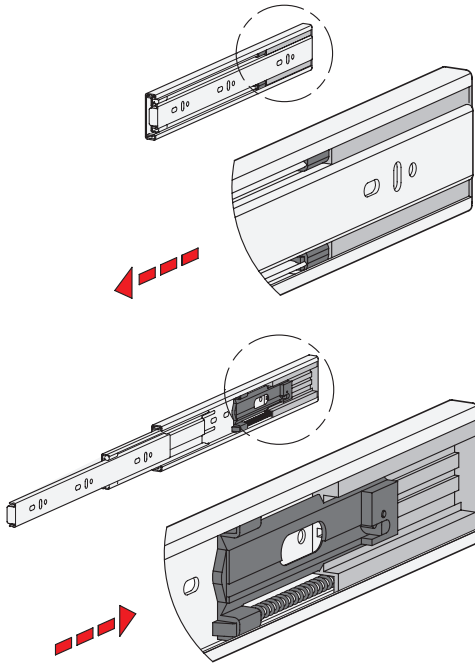

Telescopic slides GN 1414 have a dampened self-retracting mechanism, which is also called “soft-close”. The dampened self-retracting mechanism is divided into two main functions and offers the best possible ease of use on closing the extension.

The self-retracting mechanism takes over the automatic retraction of the slides on the last 47 mm of stroke in the back stop position, where the slides are held in place accordingly. The retraction force is about 40 newtons per slide pair. Also, the dampening mechanism slows down to a considerably reduced speed the closing movement on the said stroke. An extremely smooth and gentle closing movement is achieved. This retraction force has to be overcome accordingly on opening the extension.

The dampened self-retracting mechanism is designed for loads weighing up to 36 kg based on 60,000 cycles (LGA standard). Proper use, including the reduction of the stroke speed to no more than 0.15 m/s on reaching the retraction mechanism, as well as compliance with the load values are required.

In this slide variant the available retraction force can be regarded as a locking device, which is noticeable through a slight restriction on opening the extension.

## Detach function

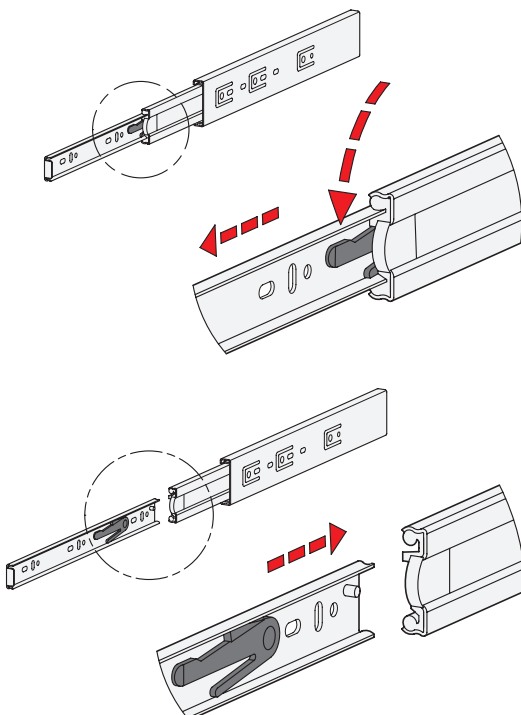

Type F has additionally a detach function through which the extension slides can be completely separated from one another in the area of the middle and inner slide. This feature not only facilitates mounting. It also allows the extension to be quickly removed, for example, when frequent maintenance work is performed on the components located behind.

The telescopic slide can be quickly and easily detached in the extracted position through activation of the release lever, allowing the inner slide to be removed from the front.

For reattaching the slides, the ball cages need to be moved to the front end position. Then the inner slide is inserted to the back end stop where it locks into place automatically.

The protected arrangement of the release mechanism prevents accidental detachment of the slide.

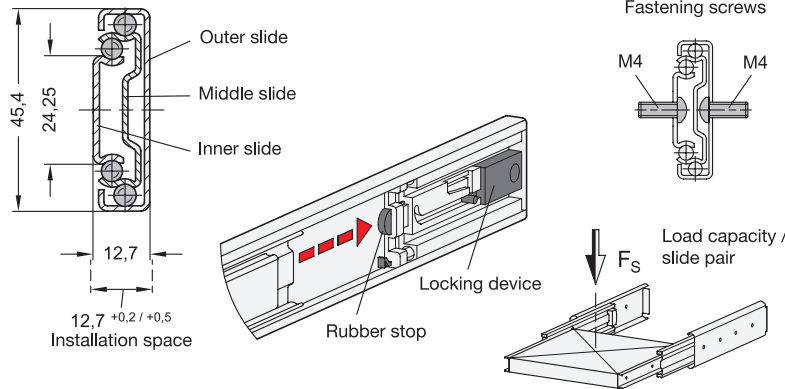
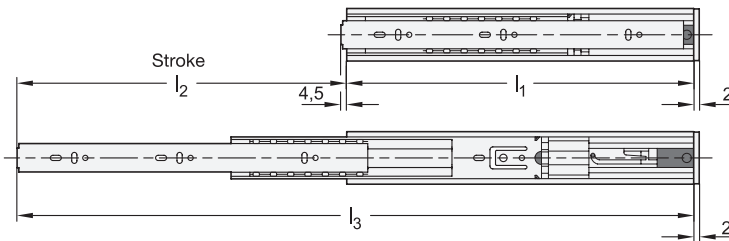

- 2 Type**  
F with rubber stop, locking device in back, detach function
- 3 Identification no.**  
1 Fastening using through-holes

**1**

$l_1$	$l_2$ <sup>+3</sup> Stroke	$l_3$	$F_S$ per pair in N	
			at 10,000 cycles	at 100,000 cycles
350	350	700	380	290
400	400	800	430	340
450	450	900	430	340
500	500	1000	380	290

**1**

$l_1$	$l_2$ <sup>+3</sup> Stroke	$l_3$	$F_S$ per pair in N	
			at 10,000 cycles	at 100,000 cycles
550	550	1100	330	240
600	600	1200	300	200
650	650	1300	300	200

**Specification**

- Slide profile  
Steel, zinc plated, blue passivated **ZB**
- Bearings  
Roller bearing steel, hardened
- Ball cage, outer slide  
Plastic
- Ball cage, inner slide  
Steel, zinc plated
- Rubber stop and detach function  
Plastic / Elastomer
- Push to Open - mechanism  
Steel / Plastic
- Operating temperature -20 °C to 100 °C
- **RoHS**

**On request**

- other lengths and hole spacing
- other attachment options
- other surfaces

**Information**

Telescopic slides GN 1418 are installed vertically and in pairs. The stroke reaches  $\approx 100\%$  of the nominal length  $l_1$  (full extension). The rubber stops of type F dampen the impact of the slide in the end positions. This feature minimizes noise development and increases the lifespan. If larger static or dynamic loads occur in the direction of extension, they should be absorbed by external stop elements.

The telescopic slides are delivered in **pairs**. They can be installed on the extension on either the left or right side due to the mechanics. All mounting holes are easy to reach through auxiliary holes. Only the mounting holes are shown, but other production-related holes may be present.

see also...

- *Technical information on telescopic slides* → Page 51 ff.
- *Telescopic slides GN 1412 (with self-retracting mechanism)* → Page 16
- *Telescopic slides GN 1414 (with dampened self-retracting mechanism)* → Page 19

<p>How to order</p> <p><b>GN 1418-500-F-1-ZB</b></p>	<b>1</b> $l_1$
	<b>2</b> Type
	<b>3</b> Identification no.
	<b>4</b> Finish



## Mounting holes - outer slide

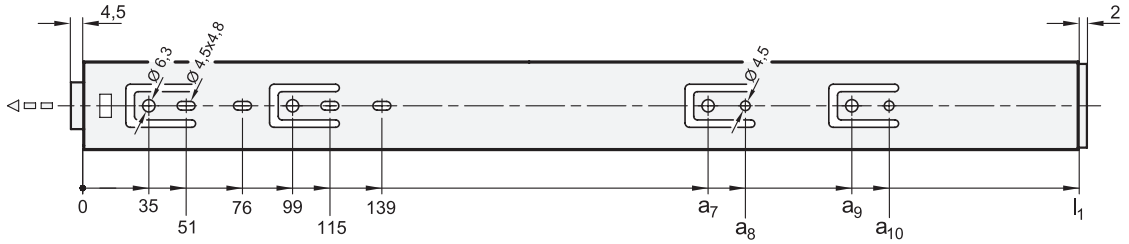

$l_1$	$a_7$	$a_8$	$a_9$	$a_{10}$
350	195	211	-	-
400	195	211	-	-
450	259	275	-	-
500	291	307	-	-
550	355	371	-	-
600	387	403	451	467
650	419	435	483	499

## Mounting holes - inner slide

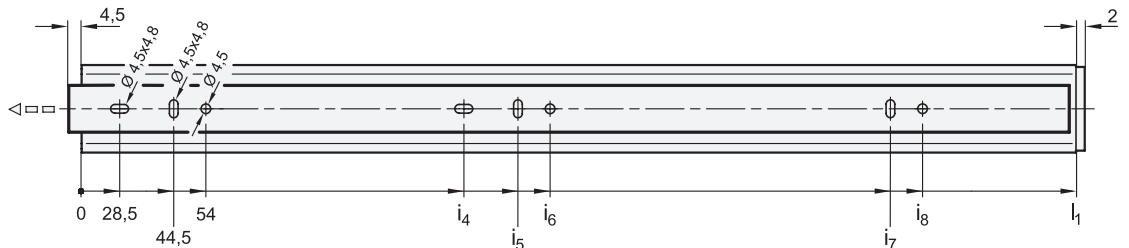

$l_1$	$i_4$	$i_5$	$i_6$	$i_7$	$i_8$
350	125	141	150,5	269	278,5
400	189	205	214,5	301	310,5
450	189	205	214,5	333	342,5
500	189	205	214,5	365	374,5
550	189	205	214,5	397	406,5
600	253	269	278,5	493	502,5
650	253	269	278,5	525	534,5

## Fastening screws

For the said loading forces  $F_S$  to be absorbed reliably in the surrounding structure, all available through-holes of the outer and inner slide having a diameter ( $\varnothing$ ) of 4.5 must be used. Alternatively, the outer slide has holes with a diameter ( $\varnothing$ ) of 6.3 for Euro screws. The elongated holes,  $\varnothing 4.5 \times 4.8$ , are used likewise for fastening and facilitate adjustment during mounting when needed. Failure to use fastening screws reduces the specified load capacity accordingly. The following screws can be used for mounting:

Designation - standard		Outer slide	Inner slide
Hexagon socket button head screw	ISO 7380	M 4	M 4
Pan head screw, Phillips	ISO 7045	M 4	M 4
Pan head tapping screw, Phillips	ISO 7049	ST 3,9 / 4,2	ST 3,9 / 4,2

## „Push to Open“ - mechanism

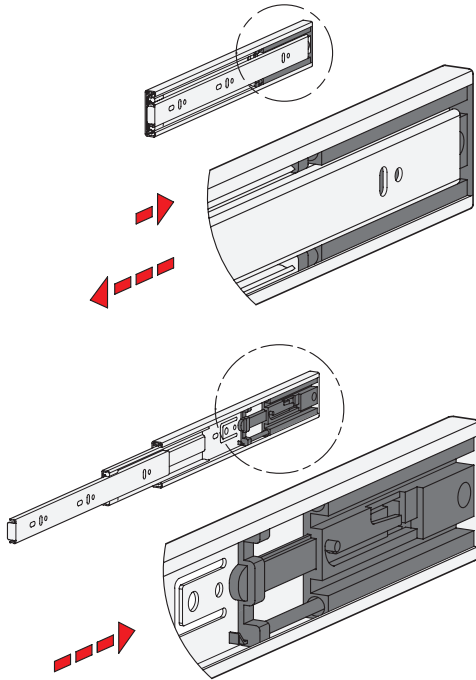

Telescopic slides GN 1418 come with a “push to open” or “touch to open” mechanism. In addition to ease of opening, the system allows you to have drawers without a front handle. The visual appearance is trim and high-end.

The drawers are actuated by pressing your hand on the front of the slide-out shelf or drawer. The required force to activate the opening mechanism is about 40 N per rail pair. The inner rail extends about 4.5 mm in its home position and can be pressed in a maximum of 8 mm in the closing direction. This should be taken into account during construction in order to prevent collisions. The pressure or release point is reached at about 3 mm which causes the drawer to slide out smoothly to about 42 mm in the opening direction after being released.

The same force has to be overcome when the drawer is closed. Over the last 42 mm, the drawer’s speed is reduced to a maximum of 0.15 m/s.

When closed, the rail is held by the opening mechanism as a type of lock.

## Detach function

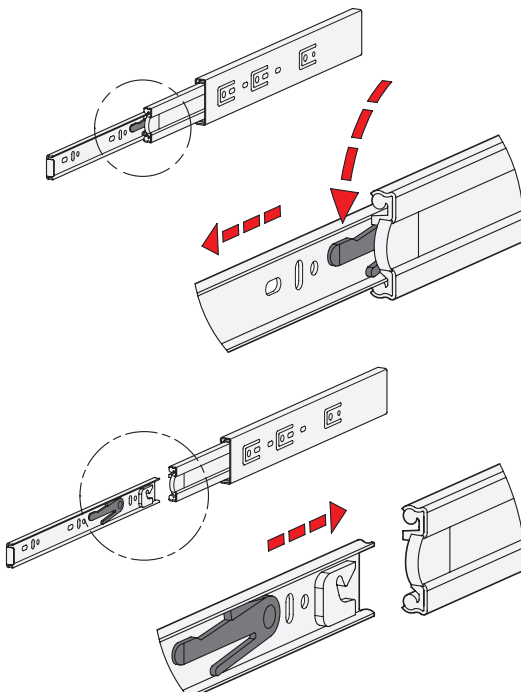

Type F has additionally a detach function through which the extension slides can be completely separated from one another in the area of the middle and inner slide. This feature not only facilitates mounting. It also allows the extension to be quickly removed, for example, when frequent maintenance work is performed on the components located behind.

The telescopic slide can be quickly and easily detached in the extracted position through activation of the release lever, allowing the inner slide to be removed from the front.

For reattaching the slides, the ball cages need to be moved to the front end position. Then the inner slide is inserted to the back end stop where it locks into place automatically.

The protected arrangement of the release mechanism prevents accidental detachment of the slide.

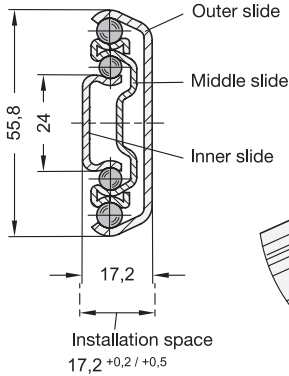
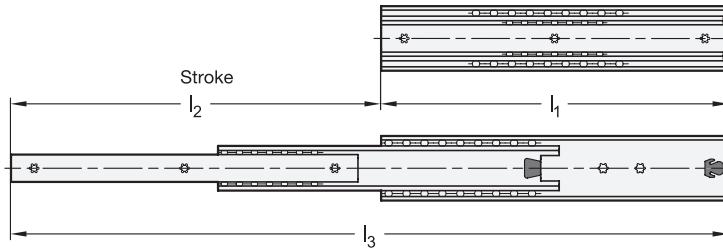

Fastening screws

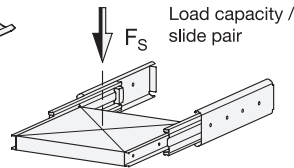
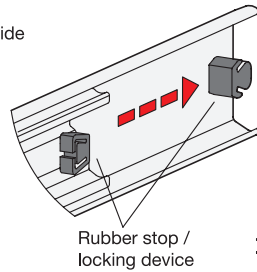
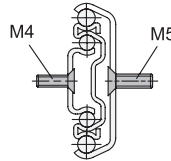

**2 Type**

**E** with rubber stop, locking device in back

**3 Identification no.**

**2** Fastening using countersunk holes

**1**

I <sub>1</sub>	I <sub>2</sub> <sup>+4</sup> Stroke	I <sub>3</sub>	F <sub>S</sub> per pair in N	
			at 10,000 cycles	at 100,000 cycles
300	320	620	940	680
350	375	725	960	770
400	440	840	970	730
450	495	945	1100	830
500	550	1050	1190	910
550	600	1150	1180	900

**1**

I <sub>1</sub>	I <sub>2</sub> <sup>+4</sup> Stroke	I <sub>3</sub>	F <sub>S</sub> per pair in N	
			at 10,000 cycles	at 100,000 cycles
600	650	1250	1230	970
700	750	1450	1290	1030
800	848	1648	1210	1020
900	950	1850	1050	900
1000	1050	2050	810	720
1200	1250	2450	640	570

**Specification**

- Slide profile  
Steel, zinc plated, blue passivated **ZB**
- Bearings  
Roller bearing steel, hardened
- Ball cage  
Steel, zinc plated
- Rubber stop  
Plastic / Elastomer
- Operating temperature -20 °C to 100 °C
- RoHS

**On request**

- other lengths and hole spacing
- other attachment options
- with latches, partially with detach function (back, front, or back-front)
- with locking device (front or back-front)
- other surfaces
- with support bracket

**4**

**Information**

Telescopic slides GN 1420 are installed vertically and in pairs. The stroke reaches ≈ 100 % of the nominal length I<sub>1</sub> (full extension). The rubber stops of type E dampen the impact of the slide in the two end positions and takes on the locking function of the back stop position. This feature is noticeable through a slight resistance on opening and closing. If larger static or dynamic loads occur in the direction of extension, they should be absorbed by external stop elements.

The telescopic slides are delivered in **pairs**. They can be installed on the extension on either the left or right side due to the mechanics. All mounting holes are easy to reach through auxiliary holes. Only the mounting holes are shown, but other production-related holes may be present.

see also...

- Technical information on telescopic slides → Page 51 ff.
- Stainless Steel-Telescopic slides GN 1460 (with full extension) → Page 46

**How to order**

**GN 1420-900-E-2-ZB**

<b>1</b>	I <sub>1</sub>
<b>2</b>	Type
<b>3</b>	Identification no.
<b>4</b>	Finish

## Mounting holes - outer slide

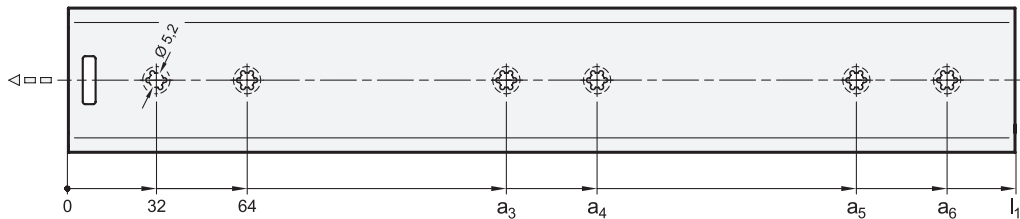

$l_1$	$a_3$	$a_4$	$a_5$	$a_6$
300	192	224	-	-
350	192	224	-	-
400	224	256	-	-
450	288	320	-	-
500	320	352	-	-
550	352	384	-	-
600	416	448	-	-
700	448	480	-	-
800	384	416	672	704
900	416	448	768	800
1000	480	512	864	896
1200	576	608	1056	1088

## Mounting holes - inner slide

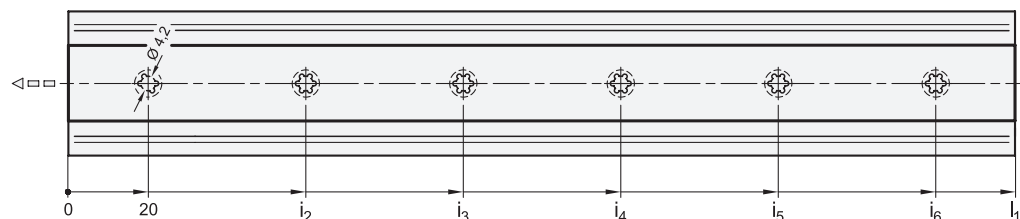

$l_1$	$i_2$	$i_3$	$i_4$	$i_5$	$i_6$
300	150	280	-	-	-
350	175	330	-	-	-
400	200	380	-	-	-
450	225	430	-	-	-
500	250	480	-	-	-
550	275	530	-	-	-
600	300	580	-	-	-
700	350	680	-	-	-
800	271	522,5	774	-	-
900	305	589	874	-	-
1000	258	497	735,5	974	-
1200	251	482	712	943	1174

## Fastening screws

For the said loading forces  $F_S$  to be absorbed reliably in the surrounding structure, all available countersunk holes of the outer and inner slide must be used. Failure to use fastening screws reduces the specified load capacity accordingly. The following screws can be used for mounting:

Designation - standard		Outer slide	Inner slide
Countersunk screw, Phillips	DIN 965	M 5	M 4
Countersunk screw, Phillips	DIN 7997	Size 5	Size 4 / 4,5

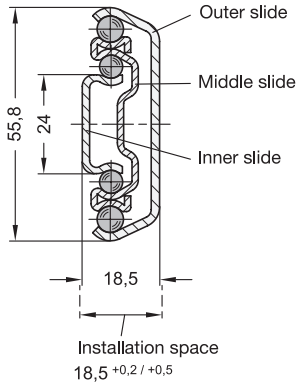
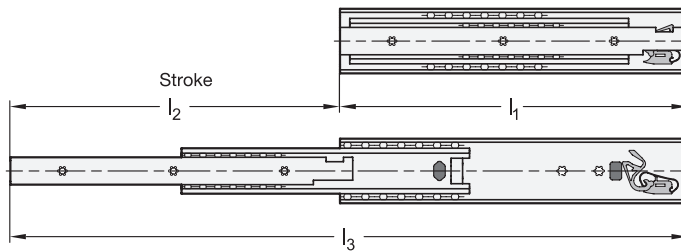

Fastening screws

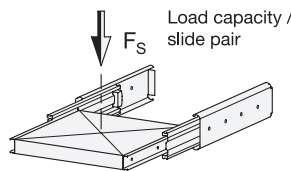
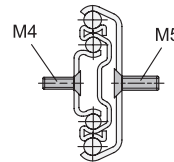

**2 Type**

**B** with rubber stop

**3 Identification no.**

**2** Fastening using countersunk holes



$l_1$	$l_2$ $\pm 4$ Stroke	$l_3$	$F_S$ per pair in N	
			at 10,000 cycles	at 100,000 cycles
300	285	585	940	640
350	350	700	960	730
400	400	800	970	770
450	450	900	1100	880
500	500	1000	1190	900



$l_1$	$l_2$ $\pm 4$ Stroke	$l_3$	$F_S$ per pair in N	
			at 10,000 cycles	at 100,000 cycles
550	550	1100	1180	980
600	600	1200	1230	990
700	700	1400	1290	1030
800	800	1600	1210	1060

**Specification**

- Slide profile  
Steel, zinc plated, blue passivated **ZB**
- Bearings  
Roller bearing steel, hardened
- Ball cage  
Steel, zinc plated
- Rubber stop  
Plastic / Elastomer
- Self-retracting mechanism  
Stainless Steel / Plastic
- Operating temperature -20 °C to 100 °C
- RoHS



**Information**

Telescopic slides with self-retracting mechanism GN 1422 are installed vertically and in pairs. The stroke reaches  $\approx 100\%$  of the nominal length  $l_1$  (full extension).

The telescopic slides are delivered in **pairs**. They can be installed on the extension on either the left or right side due to the mechanics. All mounting holes are easy to reach through auxiliary holes. Only the mounting holes are shown, but other production-related holes may be present.

see also...

- Technical information on telescopic slides  $\rightarrow$  Page 51 ff.
- Telescopic slides GN 1432 (with self-retracting mechanism)  $\rightarrow$  Page 37
- Telescopic slides GN 1424 (with dampened self-retracting mechanism)  $\rightarrow$  Page 30

**On request**

- other lengths and hole spacing
- other attachment options
- with locking device (front)
- other surfaces
- with support bracket

How to order

**GN 1422-350-B-2-ZB**

1	$l_1$
2	Type
3	Identification no.
4	Finish

## Mounting holes - outer slide

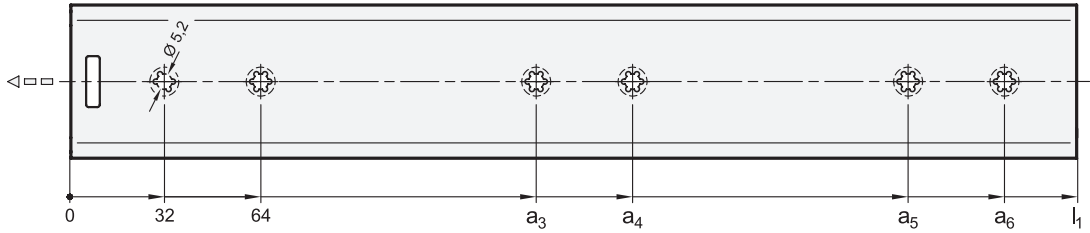

$l_1$	$a_3$	$a_4$	$a_5$	$a_6$
300	192	224	-	-
350	192	224	-	-
400	224	256	-	-
450	288	320	-	-
500	320	352	-	-
550	352	384	-	-
600	416	448	-	-
700	448	480	-	-
800	384	416	672	704

## Mounting holes - inner slide

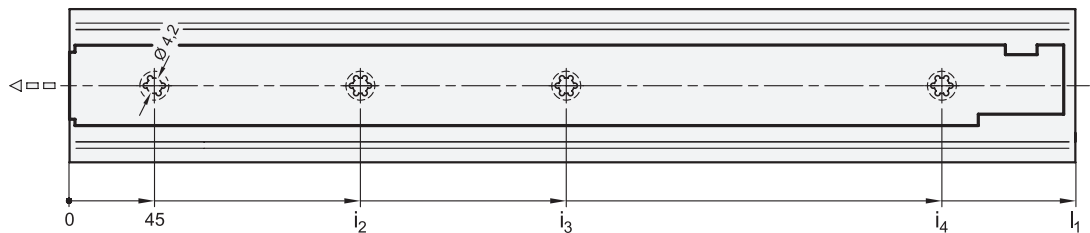

$l_1$	$i_2$	$i_3$	$i_4$
300	141	237	-
350	173	301	-
400	173	333	-
450	205	397	-
500	237	461	-
550	269	493	-
600	173	301	557
700	173	333	653
800	205	397	749

## Fastening screws

For the said loading forces  $F_S$  to be absorbed reliably in the surrounding structure, all available countersunk holes of the outer and inner slide must be used. Failure to use fastening screws reduces the specified load capacity accordingly. The following screws can be used for mounting:

Designation - standard		Outer slide	Inner slide
Hexagon socket countersunk head screw	DIN 7991	M 5	M 4
Countersunk screw, Phillips	DIN 965	M 5	M 4
Countersunk screw, Phillips	DIN 7997	Size 5	Size 4 / 4,5

## Rubber stop

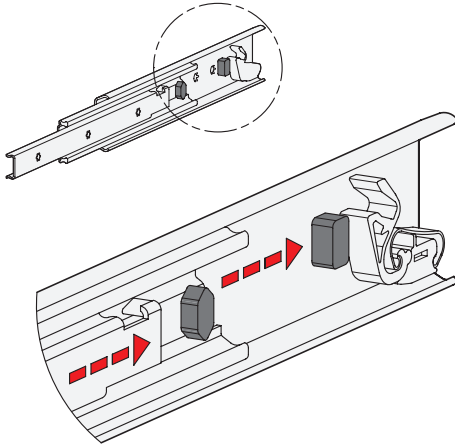

The rubber stops of type B dampen the impact of the slide in the respective end position. This feature minimizes noise development and increases the lifespan. Attached to the slides in a partially concealed, partially visible manner, the stops meet each of the requirements in regard to shape, material, and hardness.

If larger static or dynamic loads occur in the direction of extension, they should be absorbed by external stop elements.

## Self-retracting mechanism

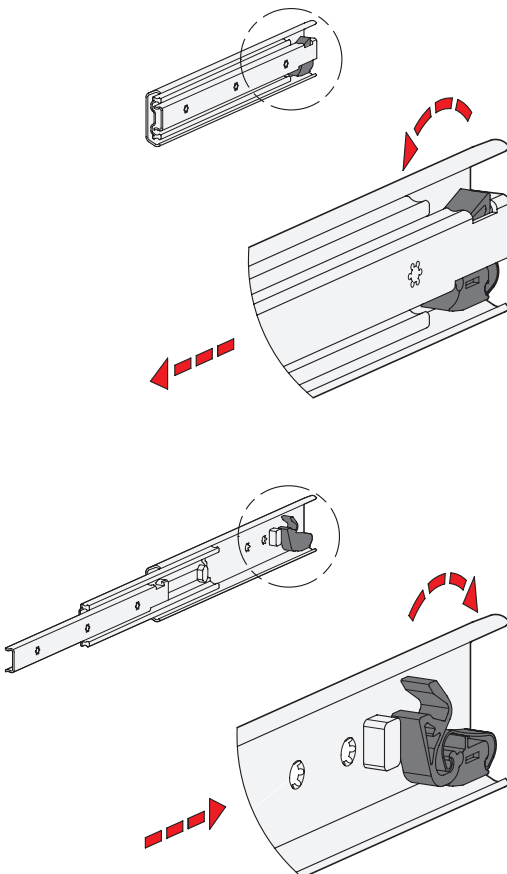

Telescopic slides GN 1422 have an integrated self-retracting mechanism, which improves considerably the ease of use when closing the extensions.

The slides are retracted and held in the back end position automatically by means of a retraction mechanism on the last 22 mm of stroke with a force of approximately 30 newtons for each slide pair. This force has to be overcome accordingly on opening the extension.

The self-retracting mechanism is also designed in such a way that it uncouples and will not be damaged when the extension is opened or closed in a jerky manner or too quickly. On the following stroke, the self-retracting mechanism clicks back into place automatically, ensuring that the function remains intact.

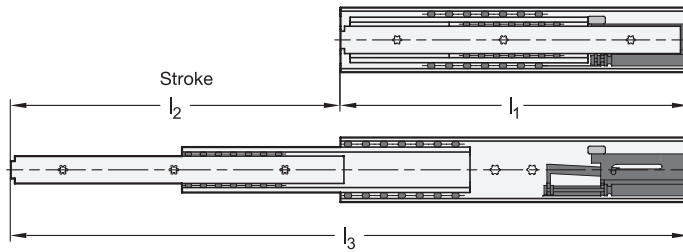

**2 Type**

**B** with rubber stop

**3 Identification no.**

**2** Fastening using countersunk holes

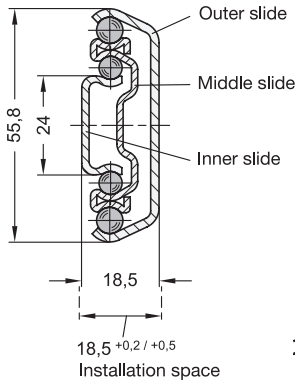

Fastening screws

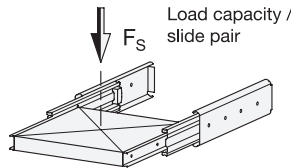
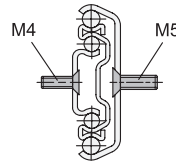

**1**

$l_1$	$l_2$ <sup>+4</sup> Stroke	$l_3$	$F_S$ per pair in N	
			at 10,000 cycles	at 100,000 cycles
350	335	685	650	570
400	400	800	750	680
450	451	901	750	750
500	506	1006	750	750

**1**

$l_1$	$l_2$ <sup>+4</sup> Stroke	$l_3$	$F_S$ per pair in N	
			at 10,000 cycles	at 100,000 cycles
550	555	1105	750	750
600	612	1212	750	750
700	700	1400	750	750

**Specification**

- Slide profile  
Steel, zinc plated, blue passivated **ZB**
- Bearings  
Roller bearing steel, hardened
- Ball cage  
Steel, zinc plated
- Rubber stop  
Plastic / Elastomer
- Self-retracting mechanism, dampened  
Stainless Steel / Plastic
- Operating temperature -20 °C to 100 °C
- RoHS

**On request**

- other lengths and hole spacing
- other attachment options
- with locking device (front)
- other surfaces
- with support bracket

**Information**

Telescopic slides with dampened self-retracting mechanism GN 1424 are installed vertically and in pairs. The stroke reaches  $\approx 100\%$  of the nominal length  $l_1$  (full extension).

The telescopic slides are delivered in **pairs**. They can be installed on the extension on either the left or right side due to the mechanics. All mounting holes are easy to reach through auxiliary holes. Only the mounting holes are shown, but other production-related holes may be present.

see also...

- Technical information on telescopic slides  $\rightarrow$  Page 51 ff.
- Telescopic slides GN 1422 (with self-retracting mechanism)  $\rightarrow$  Page 27
- Telescopic slides GN 1432 (with self-retracting mechanism)  $\rightarrow$  Page 37

How to order

**GN 1424-400-B-2-ZB**

<b>1</b>	$l_1$
<b>2</b>	Type
<b>3</b>	Identification no.
<b>4</b>	Finish



## Mounting holes - outer slide

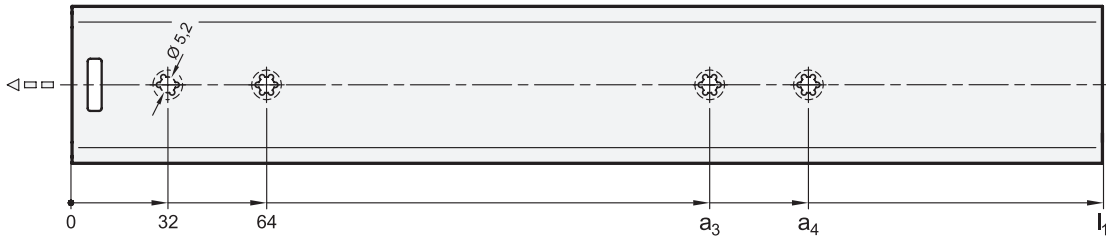

$l_1$	$a_3$	$a_4$
350	192	224
400	224	256
450	288	320
500	320	352
550	352	384
600	416	448
700	448	480

## Mounting holes - inner slide

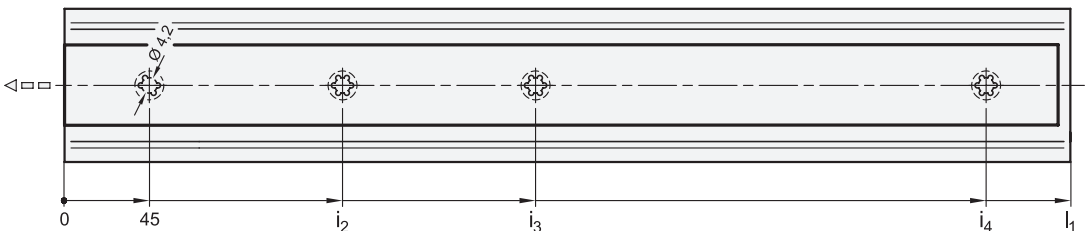

$l_1$	$i_2$	$i_3$	$i_4$
350	173	301	-
400	173	333	-
450	205	397	-
500	237	461	-
550	269	493	-
600	173	301	562
700	173	333	653

## Fastening screws

For the said loading forces  $F_S$  to be absorbed reliably in the surrounding structure, all available countersunk holes of the outer and inner slide must be used. Failure to use fastening screws reduces the specified load capacity accordingly. The following screws can be used for mounting:

Designation - standard	Outer slide	Inner slide
Hexagon socket countersunk head screw DIN 7991	M 5	M 4
Countersunk screw, Phillips DIN 965	M 5	M 4
Countersunk screw, Phillips DIN 7997	Size 5	Size 4 / 4,5

## Rubber stop

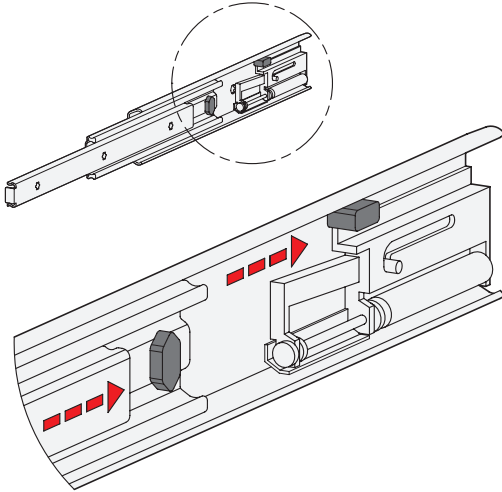

The rubber stops of type B dampen the impact of the slide in the respective end position. This feature minimizes noise development and increases the lifespan. Attached to the slides in a partially concealed, partially visible manner, the stops meet each of the requirements in regard to shape, material, and hardness.

If larger static or dynamic loads occur in the direction of extension, they should be absorbed by external stop elements.

## Self-retracting mechanism, dampened

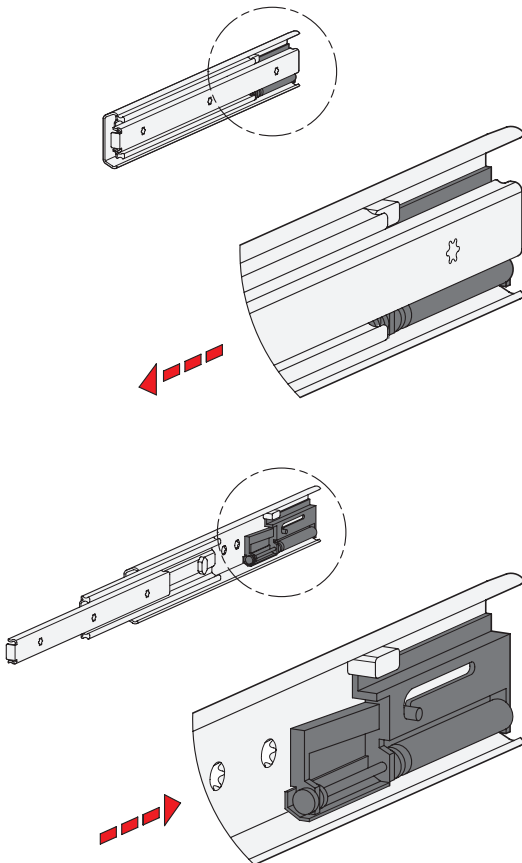

Telescopic slides GN 1424 have a dampened self-retracting mechanism, which is also called “soft-close”. The dampened self-retracting mechanism is divided into two main functions and offers the best possible ease of use on closing the extension.

The self-retracting mechanism takes over the automatic retraction of the slides on the last 40 mm of stroke in the back stop position, where the slides are held in place accordingly. The retraction force is about 35 newtons per slide pair. Also, the dampening mechanism slows down to a considerably reduced speed the closing movement on the said stroke. An extremely smooth and gentle closing movement is achieved. This retraction force has to be overcome accordingly on opening the extension.

The dampened self-retracting mechanism is designed for loads weighing up to 75 kg based on 60,000 cycles (LGA standard). Proper use, including the reduction of the stroke speed to no more than 0.15 m/s on reaching the retraction mechanism, as well as compliance with the load values are required.

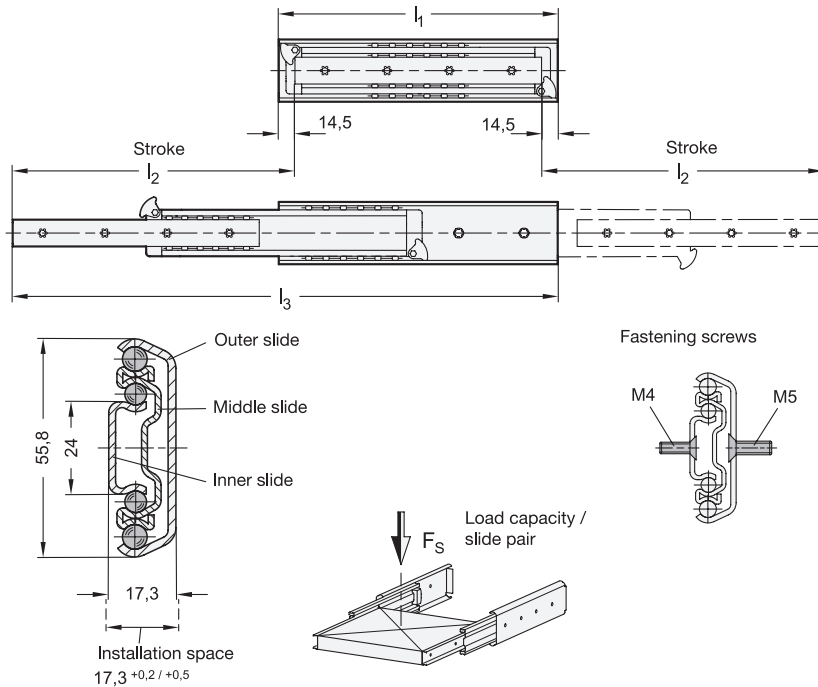

**2 Type**

**B** with rubber stop

**3 Identification no.**

**2** Fastening using countersunk holes

**1**

$l_1$	$l_2^{+4}_{-4}$ Stroke	$l_3$	$F_S$ per pair in N	
			at 10,000 cycles	at 100,000 cycles
500	503	988,5	1140	760
600	607	1192,5	1190	790
700	711	1396,5	1310	870
800	815	1600,5	1380	920

**Specification**

- Slide profile  
Steel, zinc plated, blue passivated **ZB**
- Bearings  
Roller bearing steel, hardened
- Ball cage  
Steel, zinc plated
- Rubber stop  
Plastic / Elastomer
- Operating temperature -20 °C to 100 °C
- RoHS

**On request**

- other lengths and hole spacing
- other attachment options
- other surfaces
- with support bracket

**4**

**Information**

Telescopic slides GN 1426 are installed vertically and in pairs. The special design allows the stroke to achieve  $\approx 100\%$  of the nominal length  $l_1$  on both sides (double-sided full extension). Applications such as the double-sided loading of a drawer can be realized in this way. The rubber stops of type B dampen the impact of the slide in the front end positions. If larger static or dynamic loads occur in the direction of extension, they should be absorbed by external stop elements.

The telescopic slides are delivered in **pairs**. They can be installed on the extension on either the left or right side due to the mechanics. All mounting holes are easy to reach through auxiliary holes. Only the fastening holes are shown, but other production-related holes may be present.

see also...

- Technical information on telescopic slides  $\rightarrow$  Page 51 ff.
- Telescopic slides GN 1420 (with full extension)  $\rightarrow$  Page 25

How to order

**GN 1426-800-B-2-ZB**

1	$l_1$
2	Type
3	Identification no.
4	Finish

## Mounting holes - outer slide

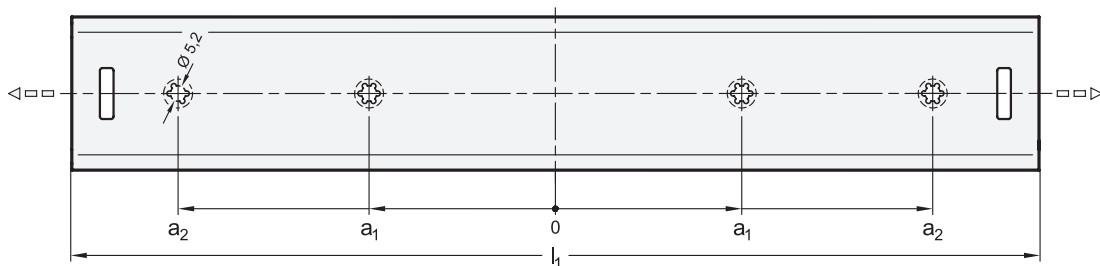

$l_1$	$a_1$	$a_2$
500	64	192
600	80	240
700	96	288
800	112	336

## Mounting holes - inner slide

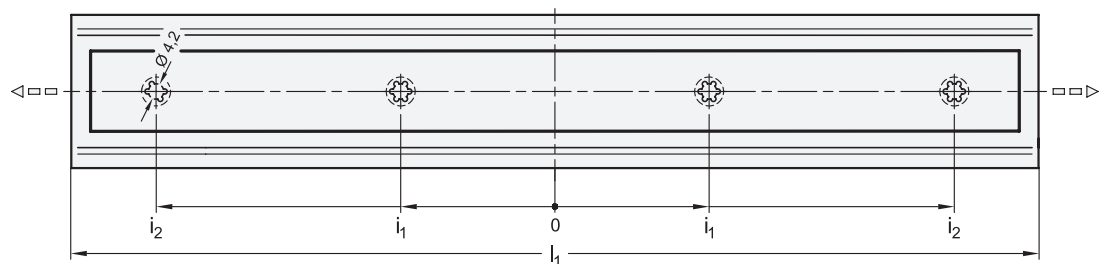

$l_1$	$i_1$	$i_2$
500	64	192
600	80	240
700	96	288
800	112	336

## Fastening screws

For the said loading forces  $F_S$  to be absorbed reliably in the surrounding structure, all available countersunk holes of the outer and inner slide must be used. Failure to use fastening screws reduces the specified load capacity accordingly. The following screws can be used for mounting:

Designation - standard		Outer slide	Inner slide
Countersunk screw, Phillips	DIN 965	M 5	M 4
Countersunk screw, Phillips	DIN 7997	Size 5	Size 4 / 4,5

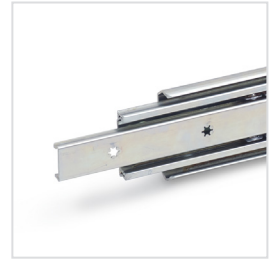
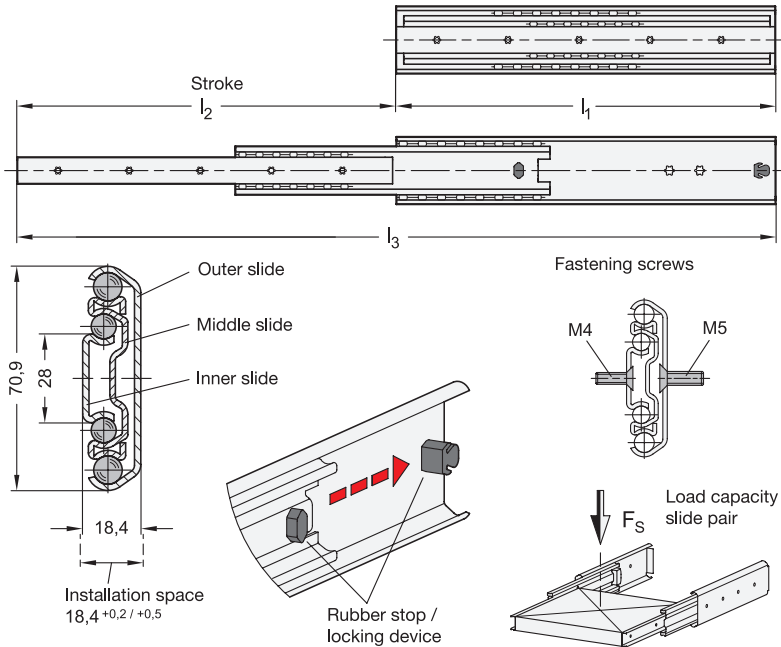

- 2 Type**  
E with rubber stop, locking device in back
- 3 Identification no.**  
2 Fastening using countersunk holes

1

l <sub>1</sub>	l <sub>2-4</sub> <sup>+4</sup> Stroke	l <sub>3</sub>	F <sub>S</sub> per pair in N	
			at 10,000 cycles	at 100,000 cycles
400	435	835	1570	970
450	485	935	1600	1030
500	545	1045	1690	1150
550	595	1145	1870	1160
600	650	1250	1890	1180

1

l <sub>1</sub>	l <sub>2-4</sub> <sup>+4</sup> Stroke	l <sub>3</sub>	F <sub>S</sub> per pair in N	
			at 10,000 cycles	at 100,000 cycles
700	750	1450	1870	1370
800	850	1650	2120	1470
900	950	1850	1920	1250
1000	1050	2050	1790	1080
1200	1250	2450	1630	950

**Specification**

4

- Slide profile  
Steel, zinc plated, blue passivated **ZB**
- Bearings  
Roller bearing steel, hardened
- Ball cage  
Steel, zinc plated
- Rubber stop  
Plastic / Elastomer
- Operating temperature -20 °C to 100 °C
- RoHS

**On request**

- other lengths and hole spacing
- other attachment options
- with latches, partially with detach function (back, front, or back-front)
- with locking devices (front or back-front)
- other surfaces
- with support bracket

**Information**

Telescopic slides GN 1430 are installed vertically and in pairs. The stroke reaches ≈ 100 % of the nominal length l<sub>1</sub> (full extension). The rubber stops of type E dampen the impact of the slide in the two end positions and takes on the locking function of the back stop position. This feature is noticeable through a slight resistance on opening and closing. If larger static or dynamic loads occur in the direction of extension, they should be absorbed by external stop elements.

The telescopic slides are delivered in **pairs**. They can be installed on the extension on either the left or right side due to the mechanics. All mounting holes are easy to reach through auxiliary holes. Only the mounting holes are shown, but other production-related holes may be present.

see also...

- Technical information on telescopic slides → Page 51 ff.
- Telescopic slides GN 1440 (with full extension) → Page 40
- St. Steel-Telescopic slides GN 1460 (with full extension) → Page 46

**How to order**

**GN 1430-1200-E-2-ZB**

1	l <sub>1</sub>
2	Type
3	Identification no.
4	Finish

## Mounting holes - outer slide

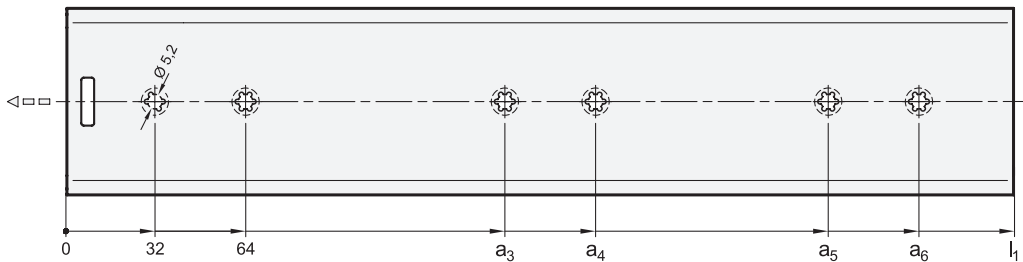

$l_1$	$a_3$	$a_4$	$a_5$	$a_6$
400	288	320	-	-
450	288	320	-	-
500	352	384	-	-
550	352	384	-	-
600	448	480	-	-
700	448	480	-	-
800	384	416	672	704
900	416	448	768	800
1000	480	512	864	896
1200	576	608	1056	1088

## Mounting holes - inner slide

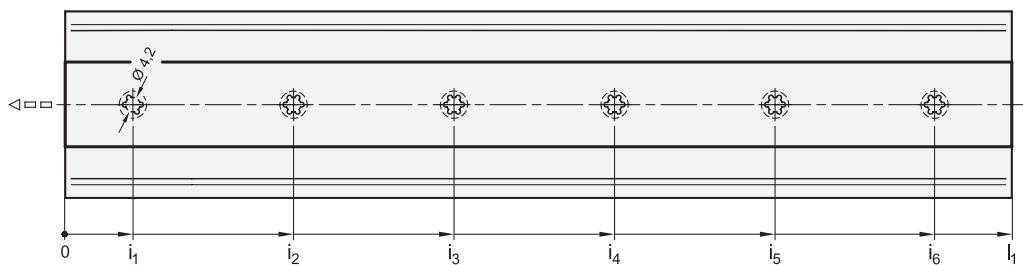

$l_1$	$i_1$	$i_2$	$i_3$	$i_4$	$i_5$	$i_6$
400	43	118	193	268	343	-
450	43	130,5	218	305,5	393	-
500	43	143	243	343	443	-
550	43	155,5	268	380,5	493	-
600	43	168	293	418	543	-
700	43	193	343	493	643	-
800	20	271	522,5	774	-	-
900	20	305	589	874	-	-
1000	20	258,5	497	735,5	974	-
1200	20	251	482	712	943	1174

## Fastening screws

For the said loading forces  $F_S$  to be absorbed reliably in the surrounding structure, all available countersunk holes of the outer and inner slide must be used. Failure to use fastening screws reduces the specified load capacity accordingly. The following screws can be used for mounting:

Designation - standard		Outer slide	Inner slide
Countersunk screw, Phillips	DIN 965	M 5	M 4
Countersunk screw, Phillips	DIN 7997	Size 5	Size 4 / 4,5

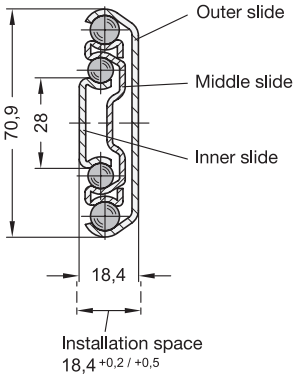
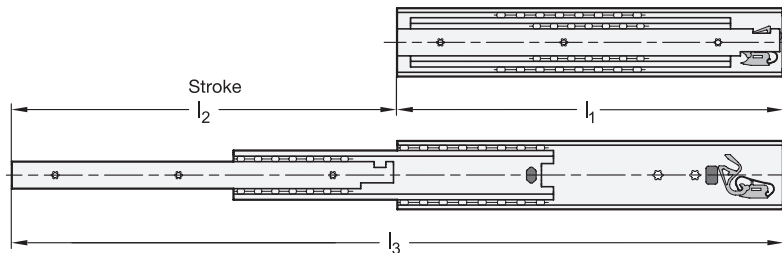

Fastening screws

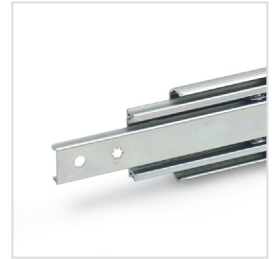
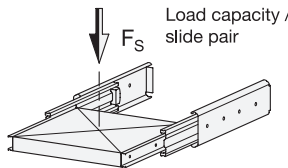
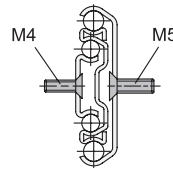

**2 Type**

**B** with rubber stop

**3 Identification no.**

**2** Fastening using countersunk holes

**1**

$l_1$	$l_2$ <sup>+4</sup> Stroke	$l_3$	$F_S$ per pair in N	
			at 10,000 cycles	at 100,000 cycles
400	400	800	1700	1030
450	450	900	1900	1160
500	500	1000	2120	1250
550	550	1100	2300	1400

**1**

$l_1$	$l_2$ <sup>+4</sup> Stroke	$l_3$	$F_S$ per pair in N	
			at 10,000 cycles	at 100,000 cycles
600	600	1200	2300	1450
700	700	1400	2280	1450
800	800	1600	2190	1550

**Specification**

- Slide profile  
Steel, zinc plated, blue passivated
- Bearings  
Roller bearing steel, hardened
- Ball cage  
Steel, zinc plated
- Rubber stop  
Plastic / Elastomer
- Self-retracting mechanism  
Stainless Steel / Plastic
- Operating temperature -20 °C to 100 °C
- RoHS

**4**

**Information**

Telescopic slides with self-retracting mechanism GN 1432 are installed vertically and in pairs. The stroke reaches  $\approx 100\%$  of the nominal length  $l_1$  (full extension).

The telescopic slides are delivered in **pairs**. They can be installed on the extension on either the left or right side due to the mechanics. All mounting holes are easy to reach through auxiliary holes. Only the mounting holes are shown, but other production-related holes may be present.

see also...

- Technical information on telescopic slides  $\rightarrow$  Page 51 ff.
- Telescopic slides GN 1422 (with self-retracting mechanism)  $\rightarrow$  Page 27
- Telescopic slides GN 1424 (with dampened self-retracting mechanism)  $\rightarrow$  Page 30

**On request**

- other lengths and hole spacing
- other attachment options
- with locking device (front)
- other surfaces
- with support bracket

How to order

**GN 1432-550-B-2-ZB**

1	$l_1$
2	Type
3	Identification no.
4	Finish

## Mounting holes - outer slide

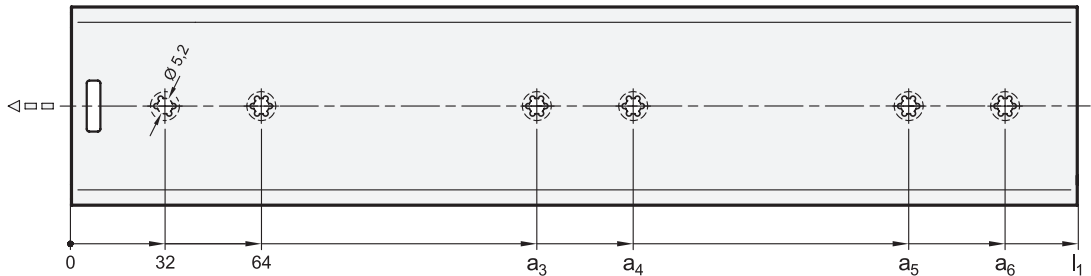

$l_1$	$a_3$	$a_4$	$a_5$	$a_6$
400	288	320	-	-
450	288	320	-	-
500	352	384	-	-
550	352	384	-	-
600	448	480	-	-
700	448	480	-	-
800	384	416	672	704

## Mounting holes - inner slide

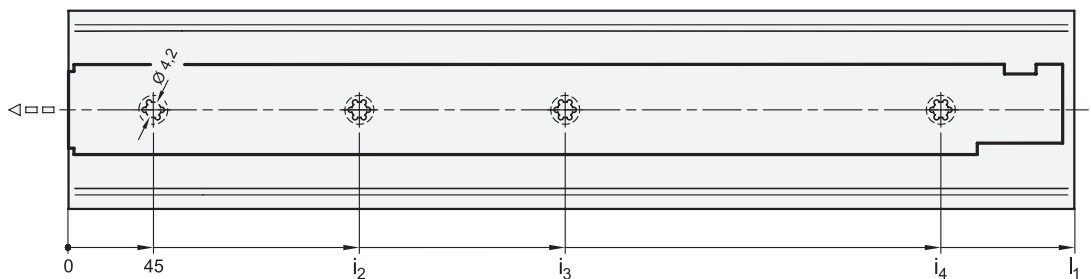

$l_1$	$i_2$	$i_3$	$i_4$
400	173	333	-
450	205	397	-
500	237	461	-
550	269	493	-
600	173	301	557
700	173	333	653
800	205	397	749

## Fastening screws

For the said loading forces  $F_S$  to be absorbed reliably in the surrounding structure, all available countersunk holes of the outer and inner slide must be used. Failure to use fastening screws reduces the specified load capacity accordingly. The following screws can be used for mounting:

Designation - standard		Outer slide	Inner slide
Countersunk screw, Phillips	DIN 965	M 5	M 4
Countersunk screw, Phillips	DIN 7997	Size 5	Size 4 / 4,5



## Rubber stop

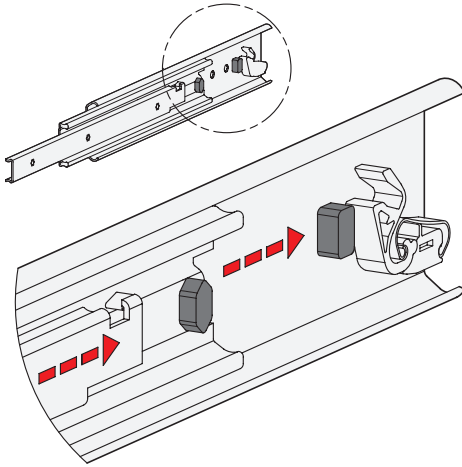

The rubber stops of type B dampen the impact of the slide in the respective end position. This feature minimizes noise development and increases the lifespan. Attached to the slides in a partially concealed, partially visible manner, the stops meet each of the requirements in regard to shape, material, and hardness.

If larger static or dynamic loads occur in the direction of extension, they should be absorbed by external stop elements.

## Self-retracting mechanism

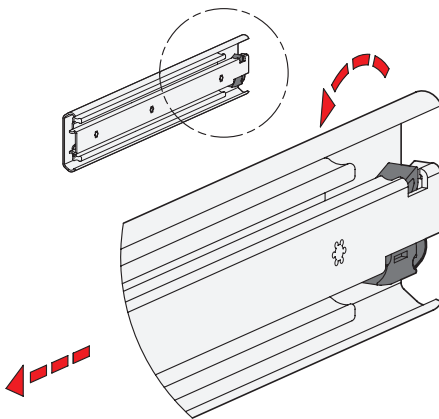

Telescopic slides GN 1432 have an integrated self-retracting mechanism, which improves considerably the ease of use when closing the extensions.

The slides are retracted and held in the back end position automatically by means of a retraction mechanism on the last 22 mm of stroke with a force of approximately 30 newtons for each slide pair. This force has to be overcome accordingly on opening the extension.

The self-retracting mechanism is also designed in such a way that it uncouples and will not be damaged when the extension is opened or closed in a jerky manner or too quickly. On the following stroke, the self-retracting mechanism clicks back into place automatically, ensuring that the function remains intact.

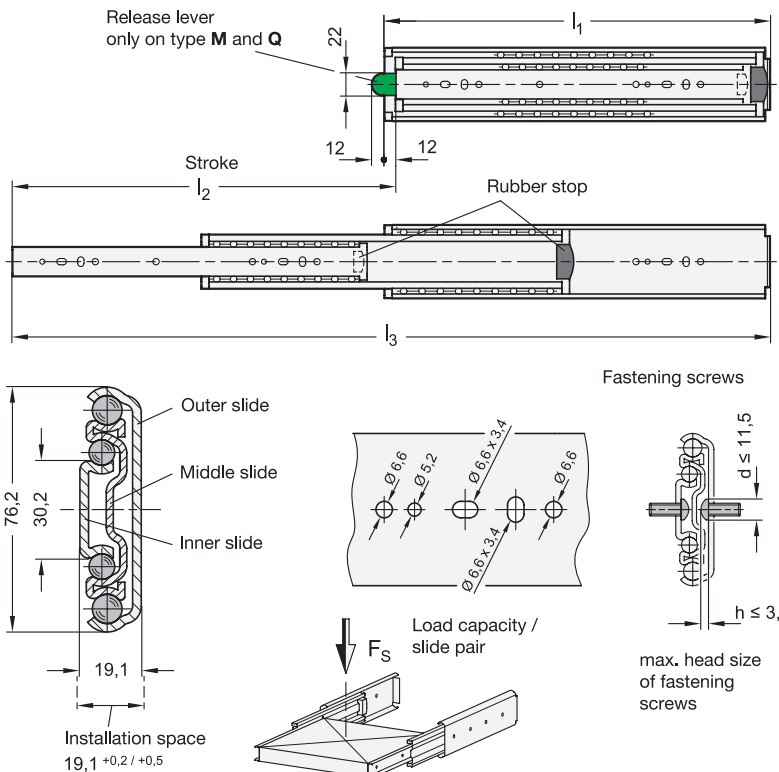

- 2 Type**
- B** with rubber stop
  - M** with rubber stop, latch in back
  - K** with rubber stop, latch in front
  - Q** with rubber stop, latch in back and in front
- 3 Identification no.**
- 1 Fastening using through-holes

**1**

$l_1$	$l_2^{+4}$ Stroke	$l_3$	$F_S$ per pair in N	
			at 10,000 cycles	at 100,000 cycles
300	298	586	2250	1575
400	398	786	2500	1750
500	512	1000	2600	1800
600	610	1198	2750	1920
700	708	1396	2950	2250

**1**

$l_1$	$l_2^{+4}$ Stroke	$l_3$	$F_S$ per pair in N	
			at 10,000 cycles	at 100,000 cycles
800	806	1594	3100	2175
900	904	1792	3200	2250
1000	1000	1988	3250	2275
1200	1212	2400	2950	2025
1500	1504	2992	2250	1575

**Specification**

- Slide profile  
Steel, zinc plated, blue passivated **ZB**
- Bearings  
Roller bearing steel, hardened
- Ball cage  
Plastic
- Latches  
Zinc die casting / Plastic
- Rubber stop  
Plastic / Elastomer
- Operating temperature  $-20\text{ }^\circ\text{C}$  to  $100\text{ }^\circ\text{C}$

• RoHS

**On request**

- other lengths and hole spacing
- other attachment options
- other surfaces

**4 Information**

Telescopic slides GN 1440 are installed vertically and in pairs. The stroke reaches  $\approx 100\%$  of the nominal length  $l_1$  (full extension). Patented plastic ball cages ensure extremely smooth running of the slide.

Telescopic slides of various types, for example, with and without latch, can be combined freely, which is why GN 1440 is delivered **as a single unit and not in pairs**. Thanks to the symmetrical design, all types can be installed on either the right or left side on the extension.

All mounting holes are easy to reach through auxiliary holes. Only the mounting holes are shown, but other production-related holes may be present.

see also...

- *Technical information on telescopic slides* → Page 51 ff.

How to order	1 $l_1$
	2 <b>Type</b>
<b>GN 1440-1500-K-1-ZB</b>	3 <b>Identification no.</b>
	4 <b>Finish</b>

## Mounting holes - outer slide

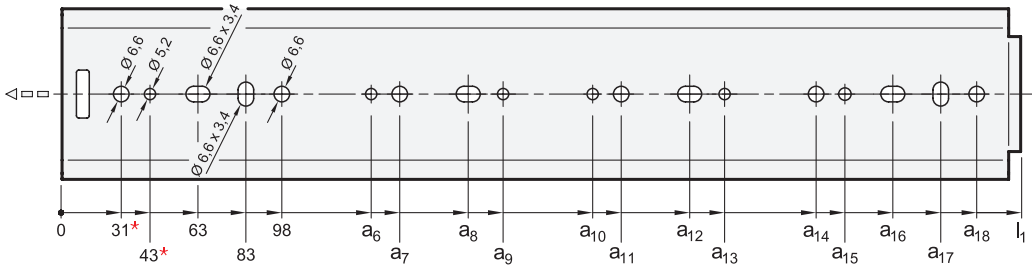

$l_1$	$a_6$	$a_7$	$a_8$	$a_9$	$a_{10}$	$a_{11}$	$a_{12}$	$a_{13}$	$a_{14}$	$a_{15}$	$a_{16}$	$a_{17}$	$a_{18}$
300	-	-	-	-	-	-	-	-	161	173	193	213	228
400	-	-	-	-	-	-	-	-	261	273	293	313	328
500	-	-	-	-	-	-	-	-	361	373	393	413	428
600	213	228	363	378	-	-	-	-	461	473	493	513	528
700	213	228	363	378	-	-	-	-	561	573	593	613	628
800	313	328	463	478	-	-	-	-	661	673	693	713	728
900	313	328	463	478	-	-	-	-	761	773	793	813	828
1000	413	428	563	578	-	-	-	-	861	873	893	913	928
1200	313	328	463	478	713	728	863	878	1061	1073	1093	1113	1128
1500	413	428	563	578	913	928	1063	1078	1361	1373	1393	1413	1428

## Mounting holes - inner slide

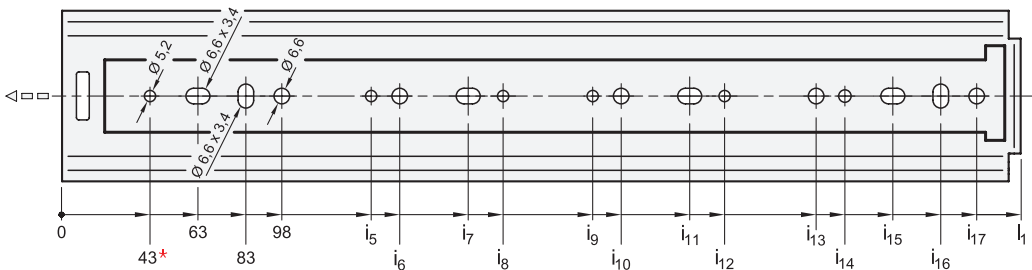

$l_1$	$i_5$	$i_6$	$i_7$	$i_8$	$i_9$	$i_{10}$	$i_{11}$	$i_{12}$	$i_{13}$	$i_{14}$	$i_{15}$	$i_{16}$	$i_{17}$
300	-	-	-	-	-	-	-	-	-	173**	-	213	228
400	-	161	-	-	-	-	-	-	261	273	293	313	328
500	-	229	-	-	-	-	-	-	361	373	393	413	428
600	213	228	398	413	-	-	-	-	461	473	493	513	528
700	313	328	463	478	-	-	-	-	561	573	593	613	628
800	313	328	498	513	-	-	-	-	661	673	693	713	728
900	413	428	563	578	-	-	-	-	761	773	793	813	828
1000	413	428	598	613	-	-	-	-	861	873	893	913	928
1200	313	328	463	478	713	728	863	878	1061	1073	1093	1113	1128
1500	413	428	563	578	913	928	1063	1078	1361	1373	1393	1413	1428

\* Bores are only usable on type B and type K. \*\* Bores are only usable on type B and type M.

## Fastening screws

For the said loading forces  $F_S$  to be absorbed reliably in the surrounding structure, all available through-holes of the outer and inner slide having a diameter ( $\varnothing$ ) of 6.6 must be used. Alternatively, holes with a diameter ( $\varnothing$ ) of 5.2 are available. The elongated holes,  $\varnothing 6.6 \times 3.4$ , facilitate adjustment during mounting when needed. Failure to use fastening screws reduces the load capacity. The following screws can be used for mounting:

Designation - standard		Outer slide	Inner slide
Hexagon socket button head screw	ISO 7380	M 5 / M 6	M 5 / M 6
Hexagon socket low cylindrical head screw	DIN 7984 / DIN 6912	M 5	M 5

### Type B with rubber stop

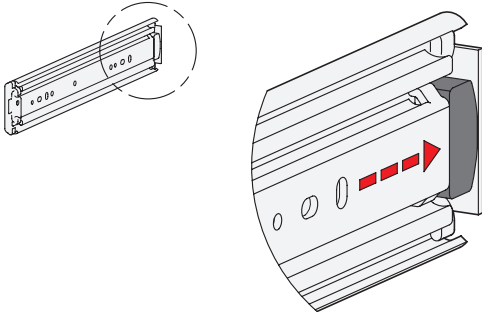

The rubber stops of type B dampen the impact of the slide in the respective end position. This feature minimizes noise development and increases the lifespan. Attached to the slides in a partially concealed, partially visible manner, the stops meet each of the requirements in regard to shape, material, and hardness.

If larger static or dynamic loads occur in the direction of extension, they should be absorbed by external stop elements.

### Type M with rubber stop, latch in back

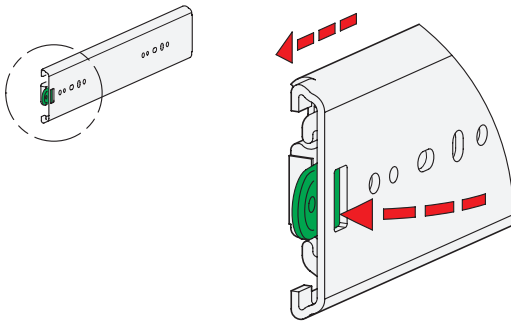

Type M is used in applications in which the slide needs to be locked in the back end position. This feature prevents the slide from extending on its own, for example, due to a tilted position. If larger loads occur in the direction of extension in the latched position, they should be absorbed by external latch elements.

The latch mechanism locks into place in a spring-loaded opening of the outer slide in the closed state. Pressing the release lever releases the inner and middle slide for extension. Back in the back stop position, the mechanism locks into place automatically in the opening of the outer slide by moving over a ramp.

### Type K with rubber stop, latch in front

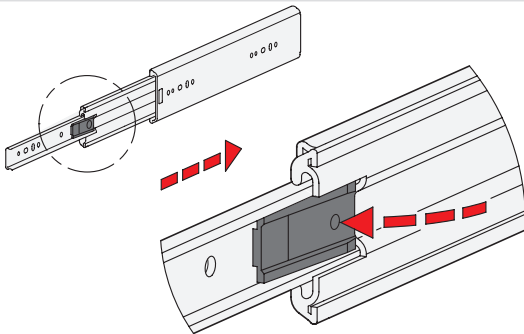

Type K is used when the extension needs to stay in the front stop position for a certain amount of time. This feature allows maintenance work to be performed when the extension is expanded, for example. If larger loads occur in the latched position, they should be absorbed by external latch elements.

For the function to be activated, the slide has to be fully extended to the front, where it will automatically click into place through a pretensioned locking lever. Pressing the lever releases the slide, allowing slide to retract again.

### Type Q with rubber stop, latch in back-front

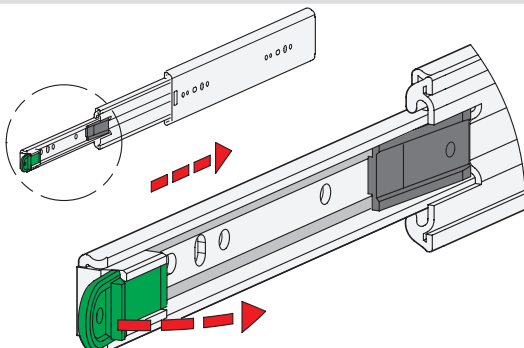

Type Q unites the properties of types M and K. The inner and middle slide lock into place in the respective end position.

Unlike the release of type K, type Q is activated through an internal rod by a convenient "remote control." The green activation lever is pressed out, the locking lever activated, and the slide released for retraction.

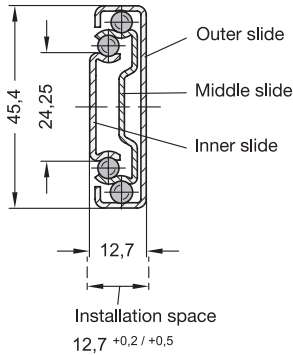
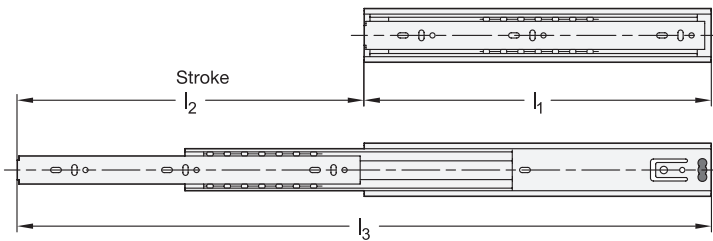

Fastening screws

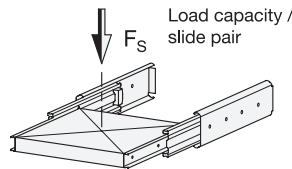
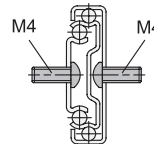

**2 Type**

**F** with rubber stop, locking device in back, detach function

**3 Identification no.**

**1** Fastening using through-holes



l <sub>1</sub>	l <sub>2</sub> <sup>+3</sup> <sub>-3</sub> Stroke	l <sub>3</sub>	F <sub>S</sub> per pair in N	
			at 10,000 cycles	at 100,000 cycles
300	300	600	460	340
350	350	700	480	360
400	400	800	510	390
450	450	900	510	390



l <sub>1</sub>	l <sub>2</sub> <sup>+3</sup> <sub>-3</sub> Stroke	l <sub>3</sub>	F <sub>S</sub> per pair in N	
			at 10,000 cycles	at 100,000 cycles
500	500	1000	480	360
550	550	1100	460	340
600	600	1200	440	340

**Specification**

- Slide profile and bearings  
Stainless Steel  
AISI 304 **NI**
- Ball cage of outer slide  
Plastic
- Ball cage of inner slide  
Stainless Steel  
AISI 304
- Ruber stop and detach function  
Plastic / Elastomer
- Lubricant  
Roller bearing grease, FDA-compliant
- Operating temperature -20 °C to 100 °C
- Stainless Steel characteristics  
→ Main Catalogue Page 1489
- RoHS



**Information**

Stainless Steel-Telescopic slides GN 1450 are installed vertically and in pairs. The stroke reaches ≈ 100 % of the nominal length l<sub>1</sub> (full extension).

The telescopic slides are delivered in **pairs**. They can be installed on the extension on either the left or right side due to the mechanics. All mounting holes are easy to reach through auxiliary holes. Only the mounting holes are shown, but other production-related holes may be present.

see also...

- Technical information on telescopic slides → Page 51 ff.
- Stainless Steel-Telescopic slides GN 1460 (with full extension) → Page 46
- Telescopic slides GN 1410 (with full extension) → Page 13

**On request**

- other lengths and hole spacing
- other attachment options

**How to order**

**GN 1450-400-F-1-NI**

<b>1</b>	l <sub>1</sub>
<b>2</b>	Type
<b>3</b>	Identification no.
<b>4</b>	Material

## Mounting holes - outer slide

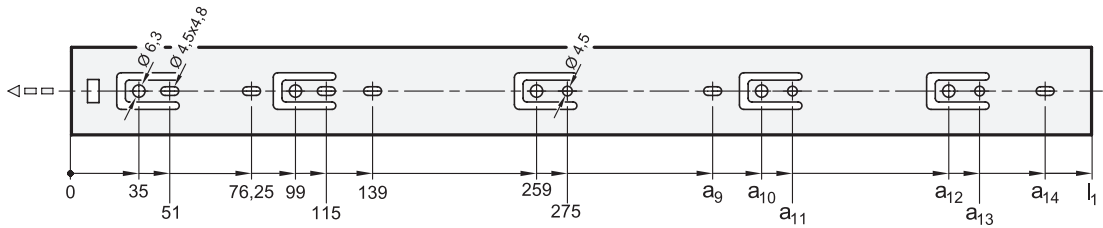

$l_1$	$a_9$	$a_{10}$	$a_{11}$	$a_{12}$	$a_{13}$	$a_{14}$
300	-	-	-	-	-	-
350	309	-	-	-	-	-
400	-	323	339	-	-	373
450	361,5	387	403	-	-	-
500	361,5	387	403	451	467	-
550	361,5	387	403	451	467	501
600	361,5	387	403	515	531	565

## Mounting holes - inner slide

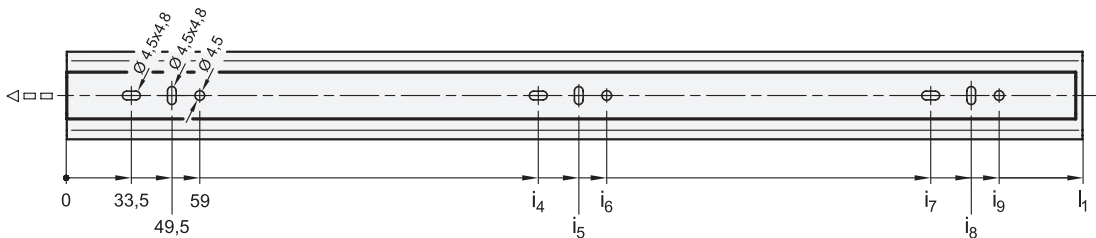

$l_1$	$i_4$	$i_5$	$i_6$	$i_7$	$i_8$	$i_9$
300	129,5	145,5	155	257,5	273,5	283
350	161,5	177,5	187	289,5	305,5	315
400	193,5	209,5	219	353,5	369,5	379
450	193,5	209,5	219	385,5	401,5	411
500	225,5	241,5	251	449,5	465,5	475
550	257,5	273,5	283	481,5	497,5	507
600	289,5	305,5	315	545,5	561,5	571

## Fastening screws

For the said loading forces  $F_S$  to be absorbed reliably in the surrounding structure, all available through-holes of the outer and inner slide having a diameter ( $\varnothing$ ) of 4.5 must be used. Alternatively, the outer slide has holes with a diameter ( $\varnothing$ ) of 6.3 for Euro screws. The elongated holes,  $\varnothing 4.5 \times 4.8$ , are used likewise for fastening and facilitate adjustment during mounting when needed. Failure to use fastening screws reduces the specified load capacity accordingly. The following screws can be used for mounting:

Designation - standard		Outer slide	Inner slide
Hexagon socket button head screw	ISO 7380	M 4	M 4
Pan head screw, Phillips	ISO 7045	M 4	M 4
Pan head tapping screw, Phillips	ISO 7049	ST 3,9 / 4,2	ST 3,9 / 4,2

## Rubber stop, locking device in back

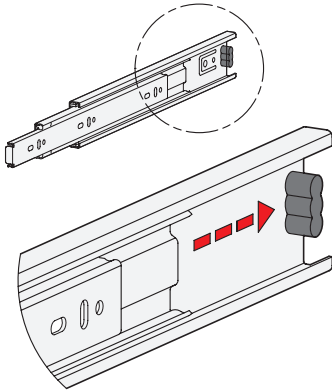

The rubber stops of type F dampen the impact of the slide in the respective end position. This feature minimizes noise development and increases the lifespan. Attached to the slides in a partially concealed, partially visible manner, the stops meet each of the requirements in regard to shape, material, and hardness.

The rubber stop takes on also a locking function in the back stop position. This feature is noticeable through a slight resistance on opening and closing the slide.

If larger static or dynamic loads occur in the direction of extension, they should be absorbed by external stop elements.

## Detach function

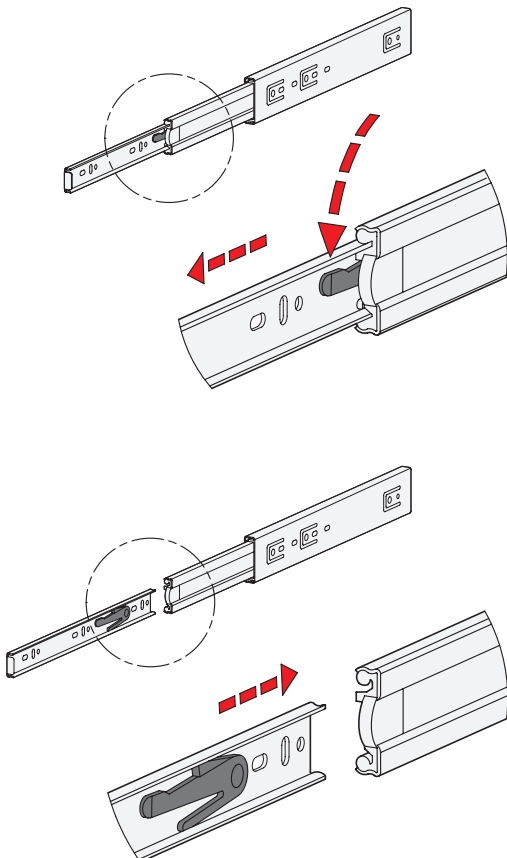

Type F has additionally a detach function through which the extension slides can be completely separated from one another in the area of the middle and inner slide. This feature not only facilitates mounting. It also allows the extension to be quickly removed, for example, when frequent maintenance work is performed on the components located behind.

The telescopic slide can be quickly and easily detached in the extracted position through activation of the release lever, allowing the inner slide to be removed from the front.

For reattaching the slides, the ball cages need to be moved to the front end position. Then the inner slide is inserted to the back end stop where it locks into place automatically.

The protected arrangement of the release mechanism prevents accidental detachment of the slide.

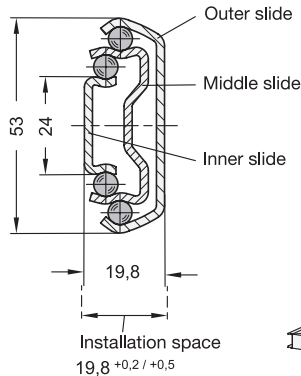
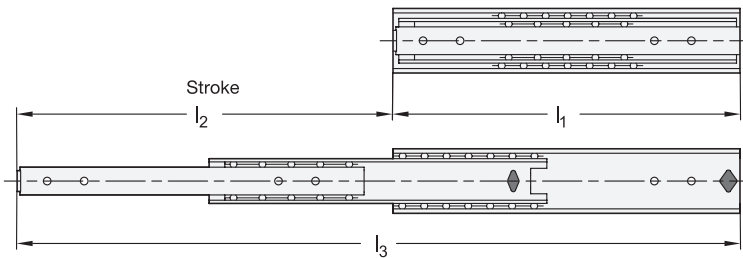

Fastening screws

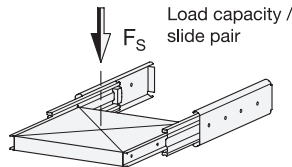
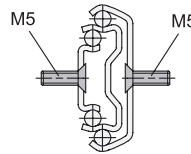

**2 Type**

**F** with rubber stop, locking device in back, detach function

**3 Identification no.**

**2** Fastening using countersunk holes

1

I <sub>1</sub>	I <sub>2</sub> <sup>+3</sup> <sub>-3</sub> Stroke	I <sub>3</sub>	F <sub>S</sub> per pair in N	
			at 10,000 cycles	at 100,000 cycles
250	274	524	750	520
300	325	625	960	660
350	374	724	980	680
400	424	824	1000	700
450	475	925	1020	710
500	524	1024	1050	730

1

I <sub>1</sub>	I <sub>2</sub> <sup>+3</sup> <sub>-3</sub> Stroke	I <sub>3</sub>	F <sub>S</sub> per pair in N	
			at 10,000 cycles	at 100,000 cycles
550	575	1125	1050	730
600	625	1225	980	680
650	675	1325	930	650
700	750	1450	880	630
750	800	1550	880	630
800	850	1650	880	630

**Specification**

- Slide profile / Bearings / Ball cage  
Stainless Steel  
AISI 304 NI
- Ruber stop and detach function  
Plastic / Elastomer
- Lubricant  
Roller bearing grease, FDA-compliant
- Operating temperature -20 °C to 100 °C
- Stainless Steel characteristics  
→ Main Catalogue Page 1489
- RoHS

**On request**

- other lengths and hole spacing
- other attachment options

4

**Information**

Stainless Steel-Telescopic slides GN 1460 are installed vertically and in pairs. The stroke reaches ≈ 100 % of the nominal length I<sub>1</sub> (full extension).

The telescopic slides are delivered in **pairs**. They can be installed on the extension on either the left or right side due to the mechanics. All mounting holes are easy to reach through auxiliary holes. Only the fastening holes are shown, but other production-related holes may be present.

see also...

- Technical information on telescopic slides → Page 51 ff.
- Stainless Steel-Telescopic slides GN 1450 (with full extension) → Page 43
- Telescopic slides GN 1420 (with full extension) → Page 25

How to order

**GN 1460-750-F-2-NI**

1	I <sub>1</sub>
2	Type
3	Identification no.
4	Material



## Mounting holes - outer slide

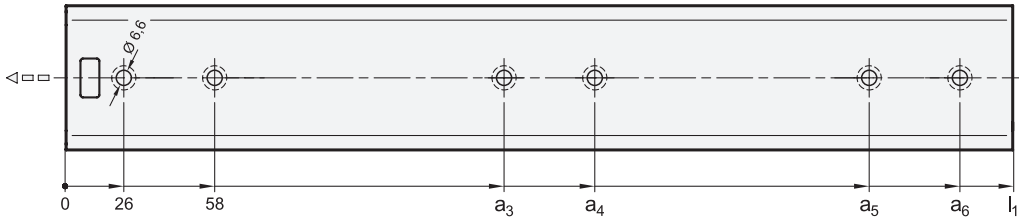

$l_1$	$a_3$	$a_4$	$a_5$	$a_6$
250	176	208	-	-
300	226	258	-	-
350	250	282	-	-
400	186	218	314	346
450	186	218	360	392
500	218	250	410	442
550	218	250	460	492
600	218	250	510	542
650	326	358	560	592
700	326	358	610	642
750	326	358	660	692
800	326	358	710	742

## Mounting holes - inner slide

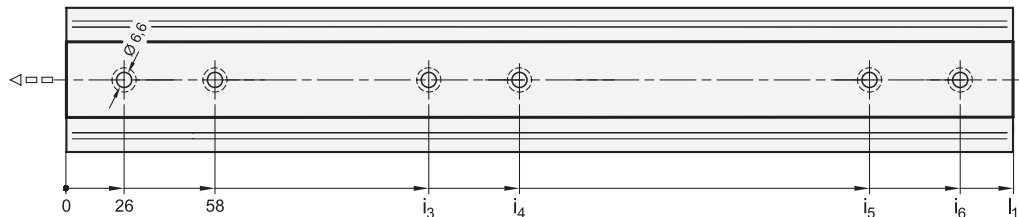

$l_1$	$i_3$	$i_4$	$i_5$	$i_6$
250	187	219	-	-
300	226	258	-	-
350	250	282	-	-
400	154	186	314	346
450	154	186	360	392
500	186	218	410	442
550	186	218	460	492
600	186	218	510	542
650	186	218	560	592
700	276	308	610	642
750	276	308	660	692
800	276	308	710	742

## Fastening screws

For the said loading forces  $F_S$  to be absorbed reliably in the surrounding structure, all available countersunk holes of the outer and inner slide must be used. Failure to use fastening screws reduces the specified load capacity accordingly. The following screws can be used for mounting:

Designation - standard		Outer slide	Inner slide
Hexagon socket countersunk head screw	DIN 7991	M 5	M 5
Countersunk screw, Phillips	DIN 965	M 5	M 5
Countersunk screw, Phillips	DIN 7997	Size 5	Size 5

## Rubber stop, locking device in back

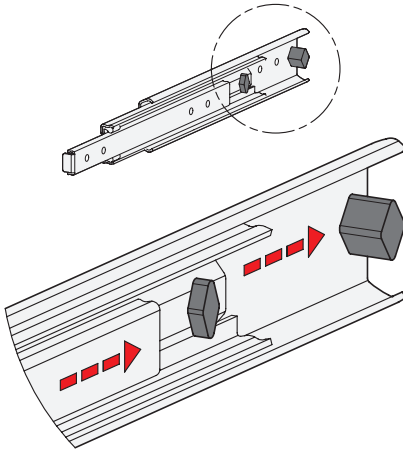

The rubber stops of type F dampen the impact of the slide in the respective end position. This feature minimizes noise development and increases the lifespan. Attached to the slides in a partially concealed, partially visible manner, the stops meet each of the requirements in regard to shape, material, and hardness.

The rubber stop takes on also a locking function in the back stop position. This feature is noticeable through a slight resistance on opening and closing the slide.

If larger static or dynamic loads occur in the direction of extension, they should be absorbed by external stop elements.

## Detach function

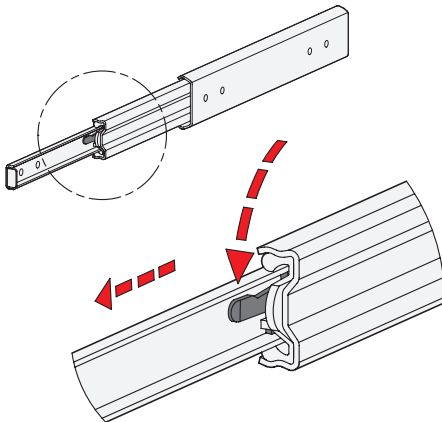

Type F has additionally a detach function through which the extension slides can be completely separated from one another in the area of the middle and inner slide. This feature not only facilitates mounting. It also allows the extension to be quickly removed, for example, when frequent maintenance work is performed on the components located behind.

The telescopic slide can be quickly and easily detached in the extracted position through activation of the release lever, allowing the inner slide to be removed from the front.

For reattaching the slides, the ball cages need to be moved to the front end position. Then the inner slide is inserted to the back end stop where it locks into place automatically.

The protected arrangement of the release mechanism prevents accidental detachment of the slide.

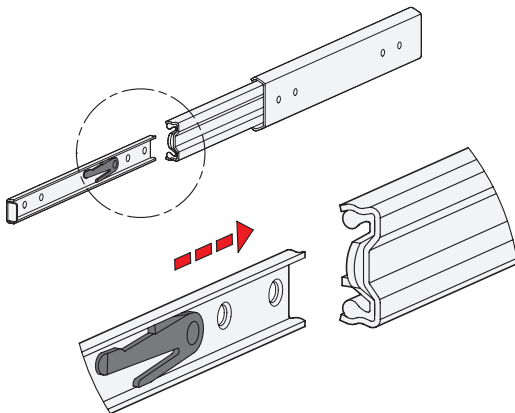

---

## General installation information

---

Follow the installation information below when mounting telescopic slides. Ideally this information should have already been taking into account in the design of the extensions. Doing so ensures smooth running, quiet, and low-wear operation of the slides over a long period of time and guarantees function in the long run.

- Telescopic slides are generally installed in pairs so that the mounting surfaces of the housing and extension side are level, parallel, and perpendicular and have to be aligned with one another correctly in regard to position. Furthermore attention should be given to adequate stability of the receiving structure so as to keep geometric errors caused by elastic deformation as minimal as possible.
- Fastening holes should be applied in such a way that excludes twisting or warping of the slides during mounting. Also the slides need to be positioned in the direction of extraction in such a way that the extensions reach the end position at the same time on retraction and extraction. In this way, an equal amount of stress acts on the rubber stops and locking devices.
- The width of the respective slide installation spaces should be designed with a tolerance of  $+0.2 / +0.5$  mm. The slides will then tension slightly in the direction of the middle of the extension. This promotes optimum performance and a long lifespan.
- Before mounting, the inner slides should be moved to the front and back stop position once to allow the ball cages to assume their intended position. Installation should also take place at room temperature.
- After mounting, check the telescopic slides and extensions for ease of movement. If something is wrong, such as sticking or warping, the cause has to be determined and eliminated through appropriate actions.

## Mounting holes, fastening screws

---

In general use all holes intended for fastening when mounting telescopic slides. Doing so will ensure that the forces resulting from the maximum load capacity  $F_S$  (nominal load) can be transferred safely from the telescopic slides from and to the surrounding structure. Failure to use fastening screws reduces the specified load capacity accordingly.

The outer and inner slides have other openings and auxiliary holes in addition to the holes intended for mounting. The catalog drawings and the CAD data available for download do not show these holes to exclude confusion and design faults. These holes are needed, among other things, for the fastening of type-dependent component features, such as the self-retracting mechanisms.

Some slide variants have fastening options for screws of various sizes. In this case, all positions of a size or type should be used. Auxiliary holes, which ensure that all mounting holes can be reached, are found accordingly in the CAD data, but are not pictured in the catalog drawings.

The type and specification of suitable screws can be found on the respective catalog pages. It is generally recommended to use screws of tensile strength class 8.8 under consideration of the specified tightening torque.

## Installation position

Telescopic slides are preferably installed arranged vertically and in pairs in a horizontal position. This ensures that the highest possible stability and torsional stiffness is reached in the smallest installation spaces and allows for absorption of the maximum load (nominal load). The performance features are optimum in this installation position, and wear is reduced to a minimum.

The horizontal or lying installation of the slide is likewise possible with certain restrictions. The maximum load in this case is only about 20 % to 25 % of the specified nominal load. The less favorable slide profile results, therefore, in considerably higher bending in the extended state. As a result, the ball cages may leave streaks on the heads of the fastening screws. In case of doubt, check the function under load in a test set-up.

Installing slides in a perpendicular position to the direction of extraction is not recommended because increased cage slip occurs in this case. This means that the upper and lower end position of the slide can be reached in some circumstances only with an increased amount of force after a few cycles since the force of gravity causes the ball cage to become dislocated from its correct position.

The following examples show possible **installation positions** of telescopic slides that are considered favorable or acceptable and some that are regarded as unfavorable and should, therefore, be avoided.

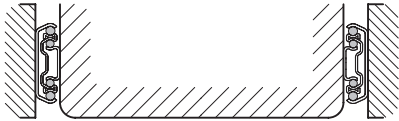
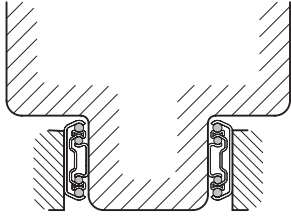
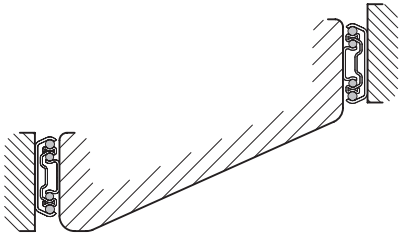
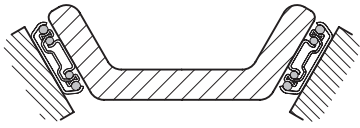
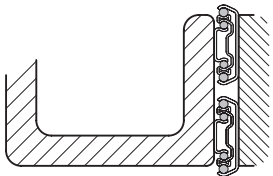
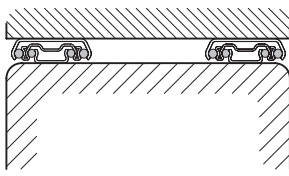
		vertically, on both sides	
favorable			
	vertically shifted, on both sides	vertically inclined, on both sides	
acceptable			
	vertically, on one side	horizontally, on both sides	
unfavorable			

## Load capacity

The maximum load capacity of telescopic slides depends on the slide profile, the nominal length  $l_1$ , and the resulting stroke  $l_2$ . Furthermore, the extension width, the slide materials used, and the parts of the component options, such as the dampened self-retracting mechanism, have a considerable influence.

The information on the maximum load capacity of the telescopic slides was determined in fatigue tests under the following conditions:

- Slide arrangement vertical in pairs
- Observance of all mounting information
- Warp-resistant test set-up
- Equal distribution of the load  $F_S$  throughout the extension finish
- Standard slide spacing of 450 mm
- 10,000 or 100,000 test cycles (one extraction and retraction = one cycle)
- Gradual increasing of load

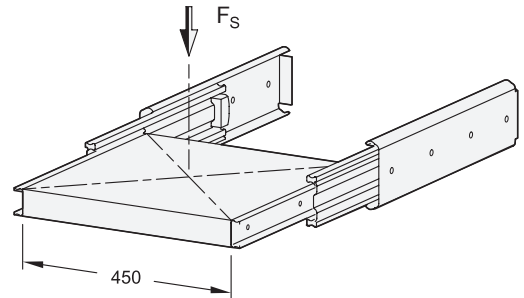

Wear, performance, and maximum bending were assessed after every test segment.

## Bending

Telescopic slides demonstrate elastic bending under load in the extended state. The bending is most noticeable at the far end of the inner slide. The general rule is that the extent of deformation may not be higher than 4.25 % of the stroke path. All slides are within this value on maximum load.

Example:

A telescopic slide having a nominal length of  $l_1 = 500$  mm is moved to the end position and stressed with the maximum load throughout the extension finish. The bending at the front-most point of the slide may now be a maximum of 21.25 mm.

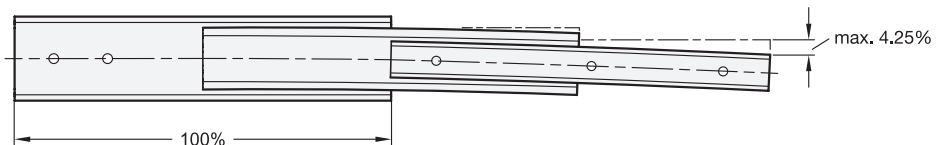

## Tolerances

All components of the telescopic slides are subject to manufacturing tolerances that ensure consistent quality and a long lifespan.

Since the stroke results from the interaction of all individual parts of the telescopic slides, the sum of all individual tolerances also has to be taken into account for the length tolerance of the stroke. In addition, slight deformation of any existing rubber stops should be mentioned. This results overall in proportionately large total tolerances that are listed on the respective catalog pages and can, therefore, be taken into account in the design layout of extensions.

## Travel speed

The permissible extraction and retraction speeds of the telescopic slides are set at a maximum speed of 0.3 m/s. Shortly before the end of stroke, the speed should be reduced to less than 0.15 m/s so that the stops, rubber stops, dampened self-retracting mechanisms etc., do not have an excessive amount of impact stress.

---

## Slide materials, surfaces and corrosion protection

---

The telescopic slides made by Ganter are manufactured out of high-quality steel or stainless steel bands.

The stainless steel telescopic slides are generally delivered with mill-finish surfaces.

The steel telescopic slides are partly made out of a pre-zinc plated steel band and are subsequently batch zinc plated and blue passivated with 5 to 7 µm. Corrosion resistance in the salt spray test for at least 72 hours against white rust is ensured in this way.

To achieve higher corrosion resistance, finish refinements can be provided on request. Two processes are available:

- Galvanically batch zinc plated 5 to 7 µm, black passivated, corrosion resistance in salt spray test for at least 120 hours against white rust
- Galvanically batch zinc plated 5 to 7 µm, passivated, electrolytically coated with T2 top coat / sealer 8 to 12 µm, corrosion resistance in the salt spray test for at least 96 hours against white rust / 500 hours against red rust

All materials and finish refinements used are RoHS compliant.

---

## Lubrication and maintenance

---

Telescopic slides are permanently lubricated with high-quality, mineral-oil-based and lead-free bearing lubricants.

For stainless steel telescopic slides, special FDA-compliant lubricants are used that are tasteless and odorless. The lubricants comply with lubricant class H1, which allows them to be used in areas where it is technically infeasible to prevent occasional contact with food. Generally direct contact can be prevented by taking appropriate actions, such as optimum placement of slides or the use of covers.

Re-lubrication is generally not necessary under normal conditions of use since the ball cages and bearings “push out” small amounts of obtained dirt from the slides when the slides move. In applications where there is heavy contamination, the slides should be cleaned from time to time with a clean cloth and then re-lubricated. Acceptable lubricants for the steel variants are, for example, Shell Alvania EP 1 and Klüberplex BE 31-222.

---

## Cage slip

---

In the event of quick changes of direction and high acceleration forces, cage slip can occur in the worst case, especially with long ball cages. In these cases, the cage does not move synchronously at half the speed of the middle and inner slides. Instead it loses its correct position gradually due to sliding. In such cases an “idle stroke” may need to be moved in the front and back stop position of the slide, at a moderate speed and under slight load to reposition the cage.

---

## Temperature of use

---

The temperature of use of telescopic slides is within the range of -20 °C to 100 °C and is determined primarily by the plastic and elastomer parts used in the slides. Depending on place of use and application, the user may have to check the function of the extensions if the temperature is at the limit.

## Information

Telescopic slides can be delivered with a number of component options. Some are available for one of the two stop positions and in combination, and they are defined by the „type“ in the article number.

The following overview shows examples of possible characteristics of the various types and component features. The components used and the employed mechanisms are adapted to match the available installation space, cross section, and structure of the selected slides and have accordingly different designs depending on slide variant. Functionality is comparable, however, and sometimes even identical.

### Rubber stops

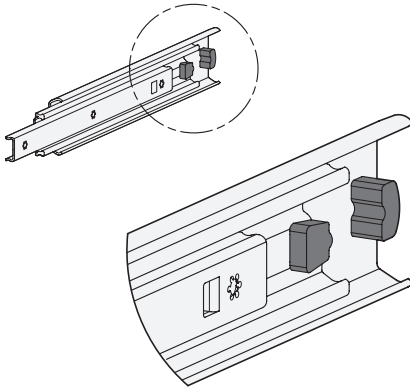

The rubber stops used in almost all slide variants dampen the impact of the slide in the respective end position. This feature minimizes noise development and increases the lifespan. Attached to the slides in a partially concealed, partially visible manner, the stops meet each of the requirements in regard to shape, material, and hardness.

If larger static or dynamic loads occur in the direction of extension, they should be absorbed by external stop elements.

### Locking devices

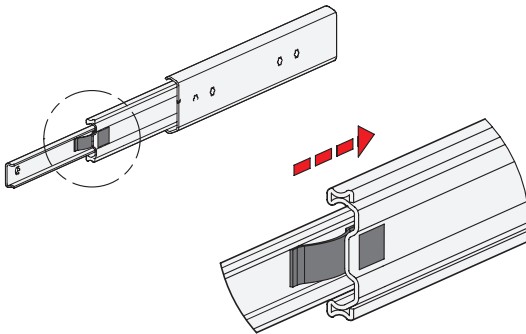

The locking function is noticeable by a slight resistance of the slides in the end positions, which has to be overcome on opening and closing. The locking device in the back stop position is usually integrated into the rubber stop function, making additional components unnecessary.

The locking device is frictionally engaged and, therefore, does not act as a positive locking latch.

### Latches

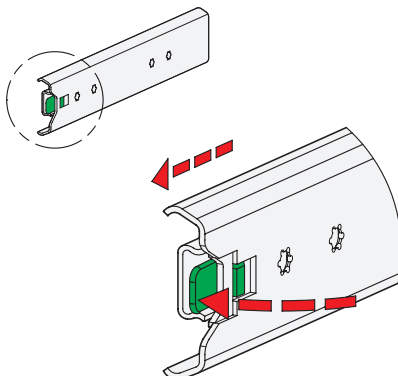

Unlike locking devices, a latch secures the slides in the stop positions in a frictionally engaged way. Telescopic slides with latches are used when the slides need to be protected against independent extension or retraction, for example, due to a tilted position.

A mechanism found within the inner slide latches automatically spring-loaded by moving over a ramp on reaching the respective stop position. Pressing the release lever releases the latch, allowing the slide to move again.

If larger loads occur in the direction of extension in the latched position, they should be absorbed by external latch elements.

## Self-retracting mechanism

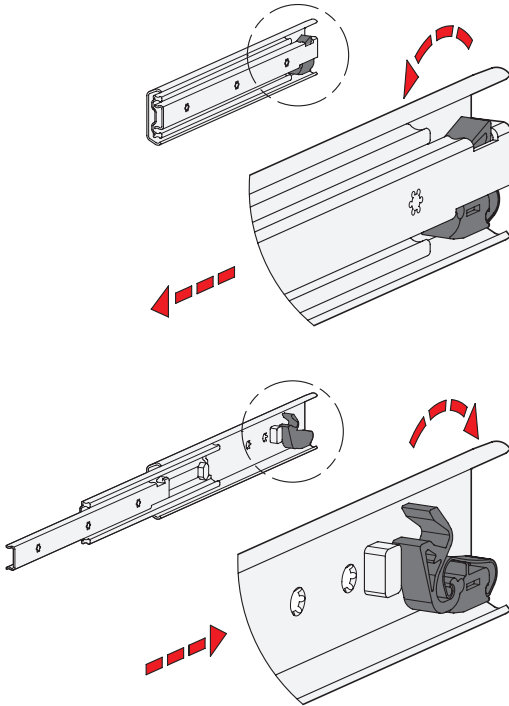

Telescopic slides can have an integrated self-retracting mechanism, which improves considerably the ease of use when closing the extensions.

In the version shown in the example, the slides are retracted and held in the back end position automatically by means of a retraction mechanism on the last 22 mm of stroke with a force of approximately 30 newtons for each slide pair. This force has to be overcome accordingly on opening the extension.

This variant is also designed in such a way that mechanism uncouples and will not be damaged when the extension is opened or closed in a jerky manner or too quickly. On the following stroke, the self-retracting mechanism clicks back into place automatically, ensuring that the function remains intact.

## Self-retracting mechanism, dampened

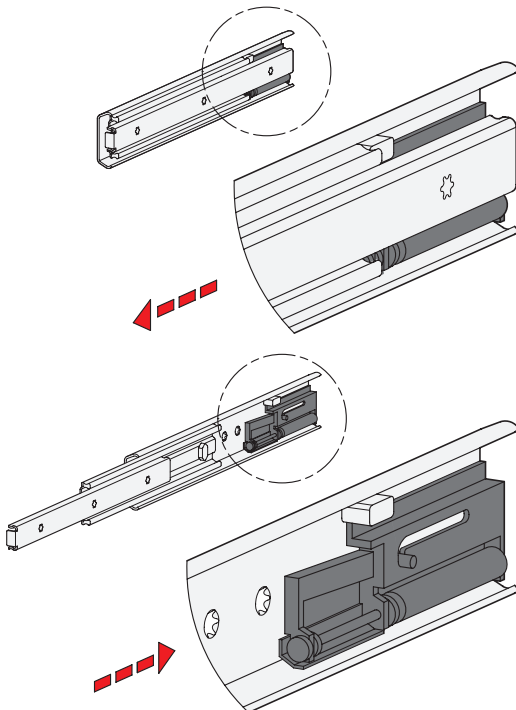

Dampened self-retracting mechanisms are also called “soft-close” and are divided into two main functions. They offer the best possible ease of use on closing the extension.

In the example shown, the self-retracting mechanism takes over the automatic retraction of the slides on the last 40 mm of stroke in the back stop position, where the slides are then held in place. The retraction force is about 35 newtons per slide pair. Also the dampening mechanism slows down to a considerably reduced speed the closing movement on the said stroke, while achieving an extremely gentle and smooth closing movement. This retraction force has to be overcome accordingly on opening the extension.

When dampened self-retracting mechanisms are used, the specified load values and stroke speeds may not be exceeded on reaching the retraction mechanism.



## Detach function

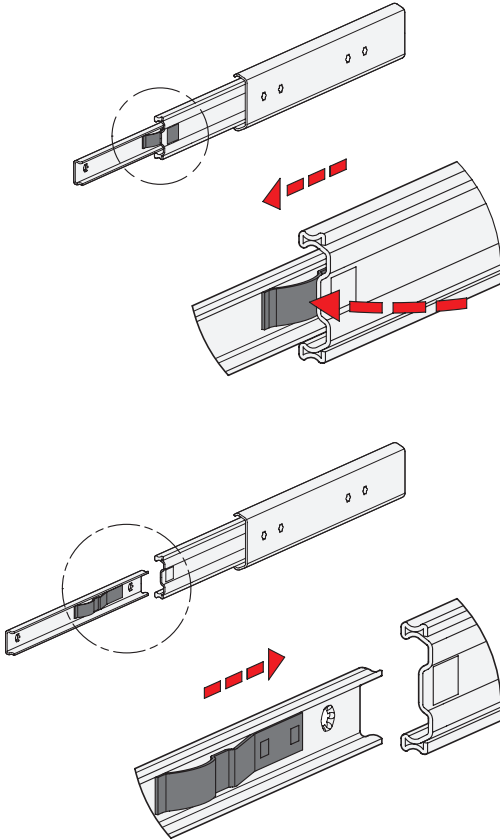

Telescopic slides with a detach function can be completely separated from one another in the area of the middle and inner slide. This feature not only facilitates mounting. It also allows the extension to be quickly removed, for example, when maintenance work is performed on the components located behind.

In the example shown, the telescopic slide can be quickly and easily detached in the extracted position through activation of a flat spring, allowing the inner slide to be removed from the front.

For reattaching the slides, the ball cages need to be moved basically to the front end position. Then the inner slide is inserted to the back end stop where it locks back into place automatically.

The protected arrangement of the various release mechanisms prevents accidental detachment of the slide.

## Support and mounting brackets

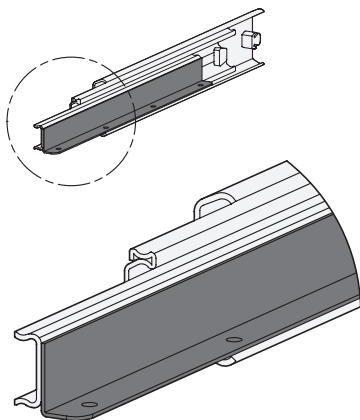

Support brackets on the inner slide are available on request for some slide variants, even in small quantities. The support bracket is used for simple fastening, for example, of a drawer, if side mounting is not possible. Fastening occurs by means of through-holes that are arranged at a right angle in the bracket.

The fastening screws secure only the position of the drawer in this case. Additional reinforcement of the slides themselves, as with side mounting, is not possible. The drawers should therefore be designed as rigidly as possible so that the perpendicular load does not introduce any unnecessary tension through the support bracket into the slides.

## „Push to Open“ - mechanism

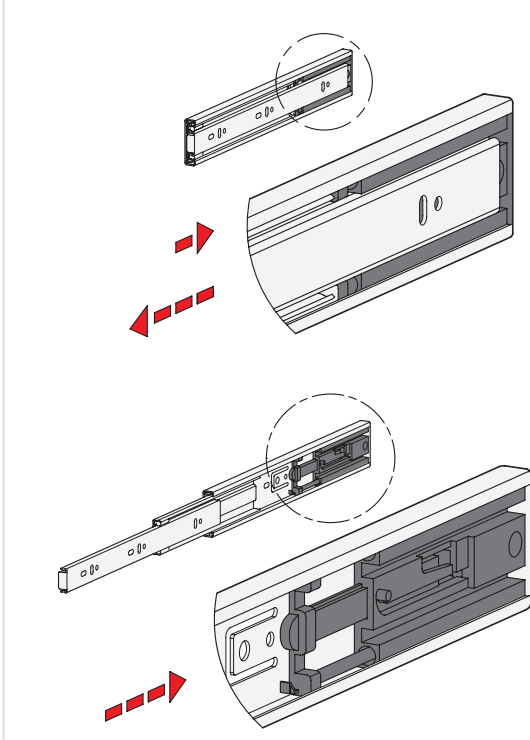

Telescopic slides can be fitted with a “push to open” or “touch to open” mechanism. In addition to ease of opening, the system allows you to have drawers without a front handle. This makes it easy to achieve a sleek, high-end appearance.

The system is typically actuated by pressing your hand on the front of the slide-out shelf or drawer.

In the example shown here, the required force to activate the opening mechanism is about 40 N per rail pair. The inner rail extends 5 mm in its home position and can be pressed in by about 8 mm in the closing direction. This should be taken into account in the design in order to prevent collisions. The pressure or release point is reached at about 3 mm, which causes the drawer to slide out smoothly to about 40 mm in the opening direction after being released.

When using telescopic slides with “push to open” actuation, the load values and travel speeds upon reaching the retraction mechanism as specified in the respective standard sheet may not be exceeded.

## Information

In addition to the standard fastening of telescopic slides, with through-holes or countersunk holes, other fastening variants can be provided on request. Possible fastening types can be implemented on the inner or outer slide and in combination depending on the requirement. Some examples are shown below. Other, customer-specific special fastenings are also possible after feasibility has been checked.

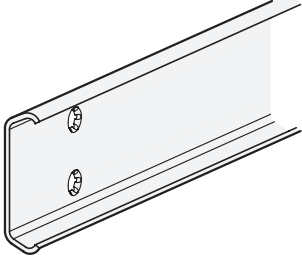
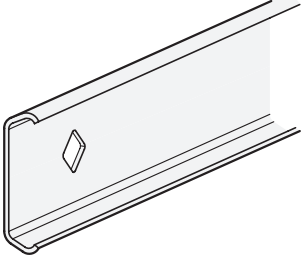
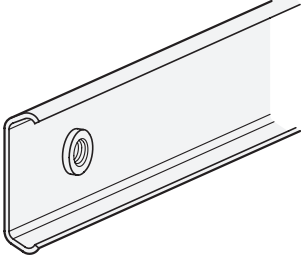
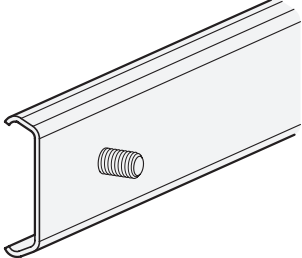
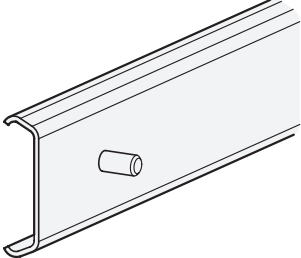
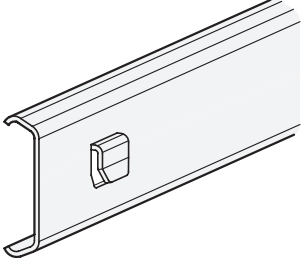
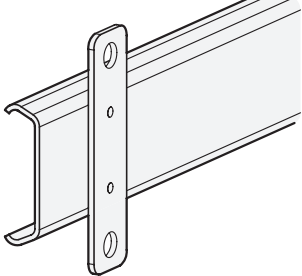
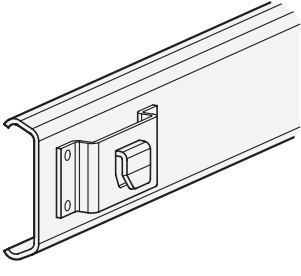
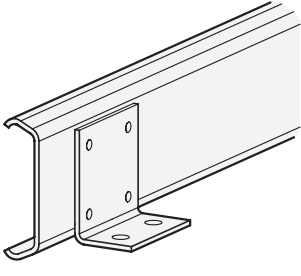
Countersunk holes	Other fastening holes	Press nuts
		
Threaded studs / bolts	Mounting studs / bolts	Fastening clips
		
Mounting plates, spot-welded	Spacers, spot-welded	Support brackets, spot-welded
		

**Otto Ganter GmbH & Co. KG**

Triberger Straße 3  
78120 Furtwangen  
Germany

**Tel.** +49 7723 6507-0

**Mail** info@ganternorm.com

**[www.ganternorm.com](http://www.ganternorm.com)**